

Wastewater lifting plants
and pumping stations

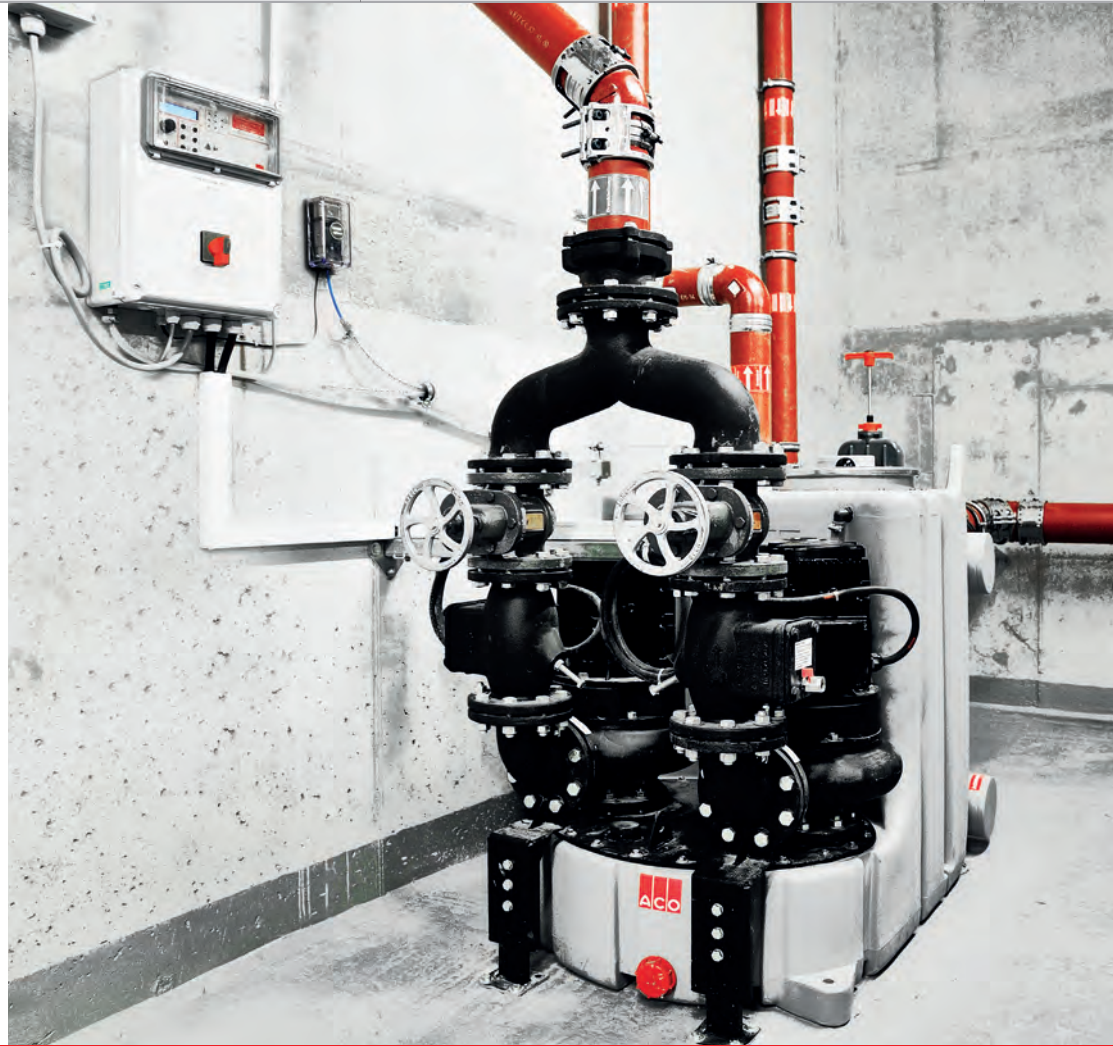

Active drainage below the backflow level

**Wastewater lifting plants and pumping stations
for trade and industry**

ACO. The future of drainage.



The ACO system chain creates the drainage solutions for the environmental conditions of tomorrow

Increasingly extreme weather events require ever more complex drainage concepts. To this end, ACO creates clever system solutions, which function in both directions: They protect people from water – and vice versa.

Each ACO product within the ACO system chain secures the route of the water with the objective of being able to recover it in a way that makes ecological and economic sense. Within the ACO Group, ACO Building Drainage supports the global system chain and combines system solutions for drainage, separation and pumping to form integrated drainage concepts within buildings.



collect:
Collect and carry

- Floor drainage
- Bathroom drainage
- Roof drainage
- Parking deck drainage
- Balcony and terrace drainage
- Pipe systems



clean:
Pretreat and treat

- Grease separators
- Starch separators
- Light oil separators
- Process engineering



hold:
Hold and retain

- Backflow systems



release:
Pump, discharge and reuse

- Lifting plants
- Pumping stations



ACO system chain
in action

Contents

Products for all requirements	04
<hr/>	
Basic Principles and Technical Information	06
Causes and risks due to backflow	06
Dimensioning tools for wastewater lifting plants and pumping sta-	08
Layout and calculation	10
Installation instructions for lifting plants	12
<hr/>	
Wastewater Lifting Plants - Product Overview	15
Muli-Mini duo lifting plant for freestanding installation	16
Muli-Star DDP wastewater lifting plant for freestanding installation	18
Muli-PE-S duo wastewater lifting plant for freestanding installation	20
Muli Pro-PE K duo wastewater lifting plant for freestanding installation	22
Muli Pro-PE V duo wastewater lifting plant for freestanding installation	24
Muli Pro-PE K Parallel wastewater lifting plant for freestanding installation	26
Muli Pro-PE V Parallel wastewater lifting plant for freestanding installation	28
Muli Pro 1.x VA duo wastewater lifting plant for freestanding installation	30
Muli Pro 2.x VA duo wastewater lifting plant for freestanding installation	32
Muli Pro-PE N XL duo wastewater lifting plant for freestanding installation	34
Upstream tank plants	36
Lifting plants, system solutions for grease separators	37
<hr/>	
Pumping Stations Product Overview	45
Basic Principles and Technical Information	46
Protection against backflow	46
Layout and design	47
State-of-the-art	48
Backflow-proof installation	49
Product version	51
Muli-Max-F mono/duo prefabricated pumping station	54
Powerlift -P duo prefabricated pumping station	60
Powerlift mono/duo pump kit	62
Submersible pumps	64
<hr/>	
ACO service advantages	74
ACO 360° service – everything from a single stop	75

Products for all requirements



Supermarkets and shopping centres

You will find ACO lifting plants and pumping stations in drainage systems for supermarkets and shopping centres through to large shopping malls. The product range covers different application; on the one hand upstream and downstream of

grease separators for catering establishments and on the other hand as variants for faecal wastewater in the sanitary installations of highly frequented shopping malls.



Catering establishments

In commercial kitchens large quantities of greasy wastewater is produced by the cleaning of pots, dishes and other kitchen equipment items. Special lifting plants are required to pump the treated wastewater out of the grease separator and into the sewers; these lifting plants can easily pump the aggressive

kitchen wastewater. This mainly applies to hotels, refectories, canteens, motorway service areas and hospitals as well as restaurants in shopping centres, and kitchens where large quantities of food are grilled, fried or deep-fat fried.





Trade and industry

Pumping stations are suitable for draining large outdoor areas (e.g. ramps and inner courtyards). Due to their large usable volume they are also ideally suitable for use downstream of large-volume grease separators. In commercial units with many

employees, by choosing different pump types, faecal wastewater can also be transported. Pumping stations are frequently used where it is structurally not possible to install freestanding wastewater lifting plants.



Active backflow protection for all types of building

Rainwater, grey and black water, which arises below the backflow level must be fed without backflow into the public sewers via an automatically operating lifting plant or pumping station. This basic principle applies to detached houses precisely in the same way as it does to public buildings or industrial

plants. The objective when designing a drainage system is "to guide surface water away from the building and not to direct it into the building". Accordingly, rainfall runoff and outdoor areas must be drained via separate pumping stations outside the building.

How does backflow occur?

Public sewers sized to EN 12056-4 are designed for average rainfall events only, for purely economic reasons, and not for extreme events such as heavy rainfall. Heavy precipitation overloads the sewers and the backflowing water rises in the sewer manholes up to the backflow level. To the same extent, the backflowing wastewater pushes back into the plot drainage system of the surrounding houses.

Causes of backflow

Apart from heavy rainfall, the following events are also responsible for backflow:

- Sewer blockage or pipe bursts
- Sewer damage, e.g. cross-section reduction due to root growth
- Loss of operation in the pumping stations of the sewer operator, if the plot drainage is connected to it
- Unscheduled discharge, e.g. during sewer flushing or fire service deployments
- Increased wastewater inflow due to additional connections (e.g. extension of residential areas)

An exceptional phenomenon?

It does not always have to be a thousand year flood like the flooding of the River Elbe in 2002. In the summer of 2015, many regions in Germany were also affected by heavy rainfall events, the sewers were overloaded and many basements were flooded.

Meteorologists agree that floods and extreme rainfall events will continue to increase throughout Europe.

Annual damage amounting to millions – the question of liability and compensation

Municipalities are not liable

In May 2004, the Bundesgerichtshof, the German Federal High Court, issued a decisive judgement: Municipalities are not liable in the event of a completely unusual and rare, disastrous rainfall event. As there is no fixed "rain limit", many municipalities take the precaution of specifying in their byelaws that developers and home owners are responsible for protecting their properties against backflow and flooding. I.e. home owners must pay for backflow damage themselves. The municipalities cannot be made liable.

Insurance companies pay only conditionally

Apart from damage to private property, house owners are also liable to their tenants. There are now insurance offers

which deal with the problem of backflow. However, if the structural measures are not carried out correctly or even not at all, the insurers largely refuse liability in the event of water damage due to backflow.

- Building contents insurance: A normal building contents or building insurance does not cover damage due to floods and heavy rainfall events or resulting backflow.
- Storm and tempest damage insurance: If, in addition to their building contents or building insurance, the insured person has extended insurance protection to include storm and tempest damage, they are insured in the event of damage due to force majeure or acts of nature, for example, flooding, landslide, earthquake.

Important!

The risk of backflow is not automatically included in storm and tempest insurance and must be taken out separately! Insurance protection only exists if safety precautions such as backflow stops or lifting plants are installed for discharge points below the backflow level and these are kept operational.



Protection against backflow

The greatest possible protection against backflow can be achieved by a wastewater lifting plant whose pressure line, as in these two examples, has been routed above the backflow level.



Protection against backflow in gradient to the sewer provided by a wastewater lifting plant in multiple unit dwellings, commercial properties and detached houses with granny flat



Protection against backflow if the sewer is higher than the sanitary appliances

Backflow level

Location of the drainage points for connection to a wastewater lifting plant

Wastewater from drainage points below the backflow level, according to EN 12056, must be fed, backflow-free, into the public sewers via an automatically operating lifting plant. In addition, the following basic rule applies to rainwater from areas below the backflow level: Sur-

face water must be guided away from the building and not drawn into the building. Accordingly, rainfall runoff areas must be drained via separate pumping stations outside the building. All drainage points located above the backflow level must be drained with a natural

slope (gravity principle). The wastewater from these sanitary appliances may only be discharged via wastewater lifting plants in absolutely necessary exceptional cases (renovation of old buildings).

Overview of relevant standards

EN 12056, Published 01/2001

- Gravity drainage systems inside buildings
- Part 1: General and performance requirements
- Part 2: Sanitary pipework, layout and calculation
- Part 4: Wastewater lifting plants – Layout and calculation
- Part 5: Installation and testing, instructions for operation, maintenance and use

Work contract

As EN 12056 covers all wastewater installations in the area up to and including the outer envelope of the building, and DIN 1986-100 also covers the area of the site up to and including the site boundary (in Europe EN 752 applies from the outer building envelope up to the connection to the sewer in the road), in case of a contract award, the work contract must define the standard to which the wastewater system is to be designed and built.

EN 12050, Published 05/2015

Wastewater lifting plants for buildings and sites

- Part 1: Lifting plants for wastewater containing faecal matter
- Part 2: Wastewater lifting plants for non-faecal wastewater
- Part 3: Lifting plants for limited applications
- Part 4: Non-return valves for faecal-free wastewater and wastewater containing faecal matter

EN 12050 is the product standard for wastewater lifting plants. The application areas and construction and testing principles for the respective versions/components are defined in four parts.

- Part 1: Legal and technical provisions
- Part 5: Backflow safety valve and light liquid closures

Dimensioning tool Wastewater lifting plants and pumping stations

In the past, many manual calculations were required to find the suitable lifting plant or pumping station for a project. The pressure head losses were calculated individually with the help of diverse tables and diagrams, for example, depending on the pressure pipe dimension and flow rate. This procedure is very time consuming and requires the user to have a lot of experience. A change in a parameter frequently meant a complete revision of the design. With the dimensioning tool for wastewater lifting plants and pumping stations of ACO Building Drainage, these manual calculations are a thing of the past. The tool performs the calculations in real time and presents the results clearly and traceably.

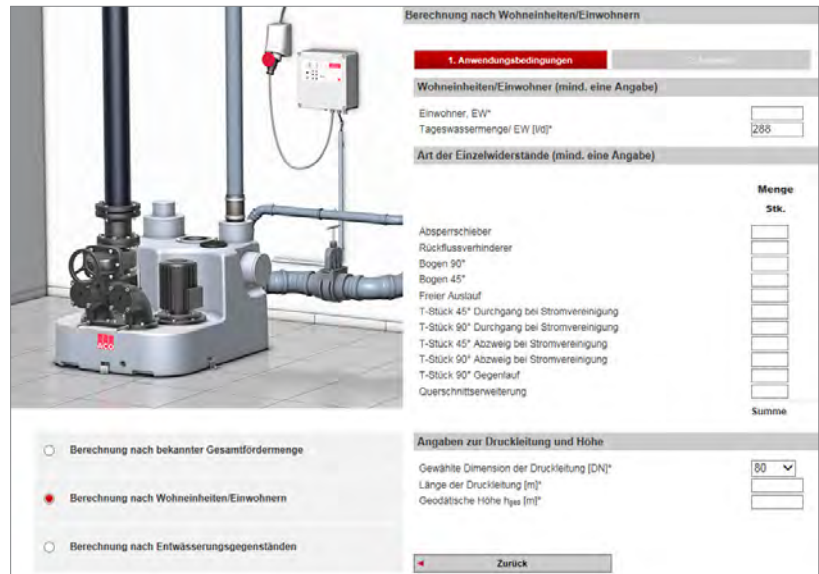

<http://catalogue.aco-haustechnik.de/en/Home/Dimensioning-tools>

Use conditions

The user has the choice between three types of design:

■ Calculation according to known total delivery rate

Here the delivery rate or capacity is predefined or known and can be entered directly. Multiple input is possible without any problems.

■ Calculation according to residential units/residents

If precise information on the sanitary appliances on site is not available, the max. flow rate can be calculated

roughly according to the number of residents. This calculation is very roughly estimated, however it can be refined by entering the daily wastewater quantity per resident.

■ Calculation according to sanitary appliances

This is the most frequently used calculation. In the first step the user enters known delivery flows, e.g. flow rate of a grease separator. The type

of use is then entered to define how frequently the sanitary appliances are used; for example a department store will expect more passing trade than a detached house; the wastewater flow rate is far higher in the department store. The calculation is always based on the extreme case: All sanitary units are in use at the same time.

Individual resistances and pressure line

In the next step the individual resistances must be entered. If it is not clear how many bends will be installed later, estimated values can also be used. Under the bottom line, more bends always means more losses.

The final step involves entering the pressure line material and other information on the pressure line (pipe).

"Standard" pipe roughness is the worst case calculation, a plastic pipe has low

roughness and thus less losses. The pipe dimension to be chosen determines which plant type can be selected later, small cross-sections allow only a very limited choice of faecal lifting plants. The length of the pressure line in turn determines how high the pressure losses are; here too an "estimated value" can be used if precise information is not available. The geodetic delivery head, also called H_{geo} , describes the level difference

between the switching off point of the pump and backflow loop. Above this level difference the pump must lift the wastewater vertically, it should then ideally be able to flow into the drain pipe itself by free fall. H_{geo} is a system constant that cannot be changed, it is therefore plotted on the y axis as the starting point for the system characteristic curve.

Selection

The calculations are clearly shown on this summary page. These include the pressure losses which are later added to H_{geo} .

$$H_{tot} = H_{geo} + H_{(V,A)} + H_{(V,R)}$$

Total delivery head = geodetic delivery head + losses in valves and fittings + losses in pipes

The theoretical operating point is a combination of the minimum flow rate and the minimum delivery head, where the minimum delivery head is set as the calculated total delivery head. The minimum flow rate is equal to the inlet flow rate, however, an additional check is made whether this also fulfils the requirements for a minimum flow velocity in the pressure line of 0.7 m/s. If not, this value is replaced by the calculated minimum flow rate. According to the standard the minimum flow rate of the pump must always be designed so that it is larger or equal to the inflowing wastewater (input flow rate <= delivery flow at the operating point).

When choosing the model, ensure that the actual operating point is larger than the theoretical operating point, i.e. the lifting plant can pump more water than necessary. It thus still has reserves. There is no generally valid statement regarding the choice. The user should select several pumps and which model suits best. The choice of usable volume, depending on the selected inlet, is important for the 3rd calculation step. The technical parameters (kW output and rpm) are shown here. The number of switching cycles per pump and hour can be calculated from the values entered previously.

A target-actual comparison is used here. The pump should not start up too frequently each hour; this leads to increased wear. A large pump with 7.5 kW and 1450 rpm, for example, should only start up a maximum 30 times an hour, while a small pump with 1.5 kW and 1450 rpm can start up approx. 80 times an hour without becoming excessively hot or wearing. An increase in the usable volume or choice of a smaller pump influences the switching frequency considerably. If no further indications appear, click "Product details" to jump directly to the corresponding online catalogue page or click Summary to create a PDF of the design.

Clarifying the preconditions

Installation space

- In the building
- In the ground, outside
- Backflow level
- Pumped medium
- Discharge conditions in the sewer

- Delivery head and pipe routing (distance from the sewer)
- Type of individual resistances (bends, stop valves, etc.)
- Dimension

Power supply

- 230/400 V
- Mains frequency 50 Hz

Designing the plant

- Wastewater inflow (connection values)
- Total delivery head (H_{geo})
- Calculation of the pump operating point

- Selection of the pressure line nominal size
- Selection of the valves and fittings required
- Checking the minimum flow velocity

- Calculation the usable tank volume
- Shaft definition
- Ventilation line

The pumps are designed and dimensioned in accordance with EN 12056-4. Here the total delivery head and the total inflow are determined.

A pump must be selected for the determined values, which at its operating point at least achieves the determined delivery head and the delivery performance (taking into account the minimum flow velocity 0.7 m/s, max. 2.3 m/s).

In the case of tank systems attention is paid to ensuring that the usable tank volume is greater than the volume in the pressure line. By complying with this requirement in EN 12056-4, the contents of the pressure line is completely replaced with each pump operation.

The following notes should be followed when dimensioning the usable volume: Pumps or lifting plants are usually

designed for S3 (intermittent operation), i.e. after switching on the pump, after the pumping operation has ended a sufficiently long pump standstill time must be available (for the motor to cool).

Selecting the plant

- Single or twin lifting plant, EN 12056-4: A twin lifting plant must be installed in systems in which the wastewater inflow must not be interrupted.

- Selecting the pump
- Selecting the controls and accessories



Layout and calculation

Which type of wastewater is produced?

Wastewater

Wastewater is the term used to describe any type of contaminated water produced in households or on commercial properties. It includes rainwater, water soiled by use, commercially used water, etc.

Domestic wastewater

Domestic wastewater is a mixture of drinking water, organic and inorganic substances in solid and in dissolved form. From experience, the substances that occur in wastewater from households mainly include human faeces, hair, food waste, cleaning products and detergents and various types of chemicals, paper, cloths and sand (e.g. in combined systems due to rainwater scouring).

However, experience also shows that all waste which is added to the system due to ignorance or failure to follow the regulations then has to be discharged through the sanitary appliance. This should always be avoided!

Grey water

Non-faecal wastewater-

Black water

Faecal wastewater.

Rainwater

Unused rainwater, which is merely soiled by air pollution, contamination due to dirt on the runoff surface. The degree of contamination primarily depends on geography, proximity to a city (air and surface soiling) and rainfall frequency. Contaminations frequently contain oil, salt or sand.

Industrial wastewater (= process water)

Industrial wastewater requires a detailed analysis of the medium, as the chemical substances in it can vary widely and therefore constitute a risk to the installation. Corrosion damage is observed most frequently. Particular attention should be paid to wastewater from the textile and food industry. Impeller type (e.g. blockaging), shaft dimensioning (due to highly different discharges) and material combinations (e.g. corrosion) of the installation are the central critical points here.

ACO MultiControl

The ACO MultiControl control series has been used in different ACO products for many years and with a very positive response. A differentiation is made between two product series:

ACO MultiControl for lifting plants and ACO MultiControl for pumping stations. The MultiControl for wastewater lifting plants is used in almost all ACO lifting plants. Among other things, this produces many advantages for the service department. The customer service department does not have to spend a long time familiarising itself with a new control in the plant and is directly familiar with the one installed.

The control has an illuminated display, via which all operating states can be read off in plain text, and parameters can be read out and changed. The most recent errors can be easily queried via the plain text display and make it easier to find the error in case of a service call-out. The switching points of the pump can be read out easily and changed if required using the rotary knob. The installed ServiceMode prevents accidental changing of the parameters.

The operating hours and an integrated switching on counter allow conclusions

to be drawn about the actual or worn condition of the pumps. Thus pumps are frequently replaced by way of precaution after a certain running time, to act before a failure can occur. An integrated amperemeter displays the consumed current while the pump is running and switches off the pumps as a precaution if the current consumption is too high. An enhanced version of the MultiControl is used for pumping stations. In addition to the functions named above it has other useful features. These include connection options for up to four float switches, a 4–20 mA pressure pick-up or the backpressure bell supplied. These options give the user free choice when it comes to measuring the level in the tank. If the 4 – 20 mA pressure pick-up is connected the level can also be transmitted to the building control system as a 4–20 mA or 0–10V signal, so that the water level in various pumping stations is always in view.

To satisfy explosion protection requirements, if the 4–20 mA pressure pick-up is used in black water the explosion barrier (accessory) is required. The integrated ATEX mode prevents the pumps from being able to be switched on if the



level falls below the switching off level, in order to prevent flying sparks on the impeller of the pump.

In addition to the fixing material and 9V block the scope of supply includes the backpressure bell with 10 m control line. Two versions are available with both isolated and non-isolated (230V) alarm outputs. These can be forwarded to the building control system or directly to a horn or warning light. A separate 230V connection is not required for this. There is no differentiation between low price and expensive plant models; the MultiControl fulfils all requirements in all application areas. Controls are used for 230V (alternating current), and 400V (three-phase current).

Which impellers are suitable for which type of wastewater?

When choosing the impeller it is important to note which design form is best for the applicable use case.

Channel impeller

The channel impeller is suitable for pumping faecal wastewater, and for pumping wastewater with solid and short-fibre solids and thick matter (pulp), sludge and organic materials. Channel impellers generally have a high

efficiency. This in turn means that the pumps usually run quietly and gently. Low-specific speed motors with lower speeds (1450 rpm) can also frequently be used, which is good for the durability of the pump(s).



Vortex impeller

The large clear space in the pump housing (free ball passage), enables the liquid to easily flow via the suction port into the pump chamber and solid and long-fibre thick matter, such as long binders, textiles, etc. can pass through the pump housing with few blockages.

Further advantage: As free-flow pumps do not have a restrictor gap between the impeller and pump housing, pumps of this type are particularly operationally reliable when used in areas with very long standstill times. Rusting of the impeller and resulting blockaging of the pump are virtually excluded here.

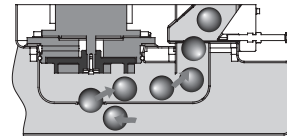

Grinder

Grinders can be used especially for fibres or solids that can be crushed. With this impeller system a grinder with cutting wheel and cutting plate is located in front of the impeller, both are connected via the motor shaft and rotate with the same speed. All solids to be pumped are cut into small particles by the grinder and are then pumped through the impeller. However, as all particles must pass through the small passages on the cutting wheel, the flow

rate is frequently highly limited as a result, however the achievable delivery head is generally far above that of a comparable free flow or channel impeller pump. This enables the wastewater to be transported over long distances or pressure lines with large level differences.

From a normative point of view a pressure line with DN 32 or larger is allowed if a pump with grinder is used.



The adaptive N-impeller

The partnership and collaboration between ACO and Xylem, which is renowned for its Flygt products, has lasted many years. In the new Muli Pro-PE N XL lifting pump the ACO Flygt N series are used, mainly in adaptive version. The advantages are obvious: constant high efficiency, no or hardly any blockages and high degree of operating liability combined with low wear. A new feature is the innovative function patented by Flygt of the adaptive N impeller, with which the impeller is able to move axially. Solids can thus pass the impeller faster and without impairment. It can

be described as an intelligent impeller, which adapts to the respective condition. The scraper and guide and relief groove ensure that solids are pumped quickly and at the same time are partially crushed. Blockaging of the volute casing is thus reduced to a minimum.

Due to the uniformly high efficiency of the adaptive N-impeller, the user is frequently able to select a pump with lower kW output compared to a competitor product: this saves energy and spares the wallet through lower initial purchasing and electricity costs.

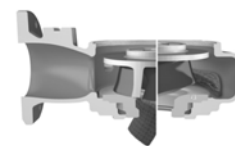
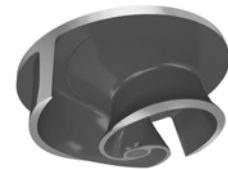

How it works: It becomes clear that the impeller lifts during the passage of the solids.

Installation instructions for lifting plants

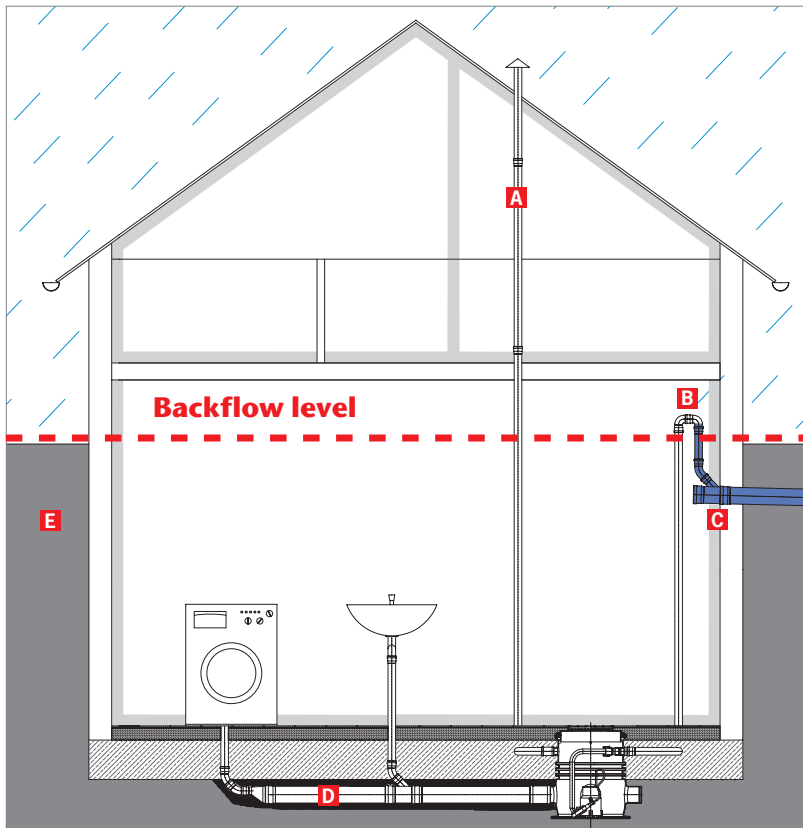

A Ventilation

- Ventilation of the lifting plants is to be routed and discharged above the roof.
- Ventilation pipe may be fed into both the main vent stack and in the secondary ventilating stack
- Ventilation of lifting plants must not be combined with or connected to the inlet side ventilation of a grease separator
- For faecal lifting plants a minimum cross-section of DN 50 must be installed
- Air admittance valves for lifting plants are not allowed

Main stack vent: Extension of a vertical grey water downpipe, whose end is open to the atmosphere, above the last connection pipe or the last connection

Ventilating stack:

Vertical ventilation pipe (vent stack), which is connected to a grey water downpipe, to limit pressure fluctuations within the grey water downpipe

B Backflow loop

- Constitutes artificially increased pipe routing above the backflow level
- Most reliable variant/protection against backflow

C Pressure line connection

- Is to be made at drains and collector drains or sewers
- The pressure line must withstand at least 1.5 times the maximum pump pressure of the plant
- EN 12056-2 and 12056-3 describe the design of the drain
- In general: Choose drain upstream of pressure line connection one nominal diameter larger
- No connection of sanitary appliances to the pressure line
- Connection of the pressure line to grey water downpipes is prohibited

D Inlet

- The inlet pipe in the wastewater lifting plant must not be reduced in the flow direction
- A stop valve is to be installed on the inlet side (repair/maintenance work)
- Drainage pipes are to be connected stress-free to the lifting plant
- The weight of the pipes and valves must be supported on site

E Surface water

- Surface wastewater, which arises below the backflow level outside the building is to be pumped separately from the domestic wastewater via a wastewater lifting plant/pumping station

Usable volume

- Pumpable volume between the switching on and switching off level of the pump
- Usable volume must be larger than the volume in the pressure line up to the backflow loop

Installation space

- Must be adequately ventilated to avoid condensation
- Must be large enough to provide a working space of at least 60 cm width and height next to and above all parts to be operated and maintained
- Adequate lighting must be available
- A pump sump is to be provided for drainage of the room

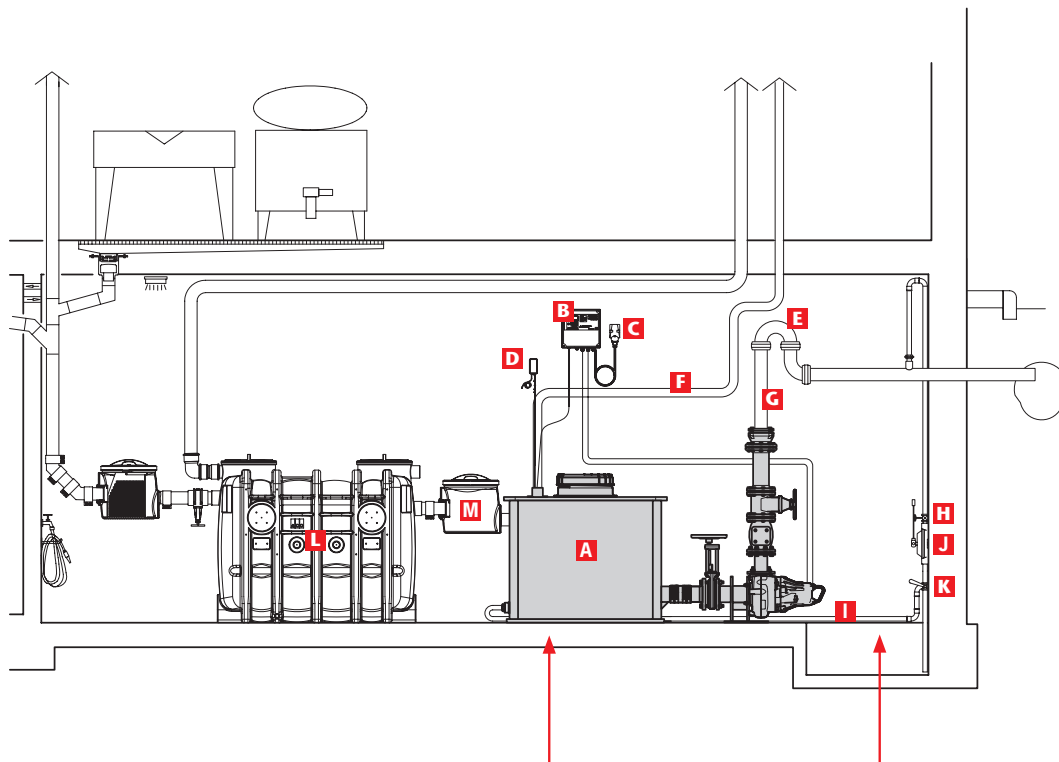

- A** Multi Pro-PE N XL duo lifting plant
- B** Pump control
- C** CEE mains socket with earth contact
- D** Air bubble injection (optional)
- E** Backflow loop
- F** Ventilation line
- G** Pressure pipe
- H** Stop valve (optional)
- I** Chamber ventilation line
- J** Manual diaphragm pump (optional)
- K** Three-way valve (optional)
- L** Grease separator (optional)
- M** Sampling pot (optional)

Buoyancy protection

- The plant must stand firmly on the floor and must be locked against rotation
- To prevent floating up in case of flooding
- To prevent damage to connections/ pipes

Electrical installation

The electrical installation must be carried out by a qualified electrician. Switching devices and signalling units must be installed in a dry, easily accessible place where the signalling unit can be easily seen and heard.

Pump sump (on site)

- For draining the installation room
- Can be drained by a manual diaphragm pump or automatically operating drainage pump in the pressure line of the lifting plant downstream of the backflow loop



Wastewater Lifting Plants – Product Overview

Apart from the installation site and delivery head, the quality of the wastewater is another important aspect for choosing the right lifting plant. Wastewater from washing machines or washbasins, so-called grey water (non-faecal wastewater), does not contain any bulky solids.

It can therefore be transported more easily than black water (faecal wastewater), which is soiled with human faeces. Lifting plants for faecal wastewater are therefore designed to easily transport solids without blocking.

ACO Multi-Mini duo lifting plant non faecal wastewater – for freestanding installation



Product advantages

- Ready to connect
- Different inlet heights selectable
- High usable volume – up to 140 l
- Toolless dismantling of the pump
- Adapted to minimum door size: 700 mm
- Low weight

Suitable for:

- Grey water
- Use downstream of grease separators up to NS 4

Product information

- Areas of use
 - Downstream of grease separators up to NS 4
 - Laundry rooms
 - Multiple shower installations
- Tank made of polyethylene
 - Bottom outlet R 1"
 - Inspection opening for easy maintenance, diameter: 340 mm
 - Connection for manual diaphragm pump DN 50
 - 4 horizontal inlet sockets DN 100
 - 1 vertical inlet socket DN 100
 - Optional 1 vertical inlet socket DN 50 (accessory)
 - 1 ventilation socket DN 70
- Delivery line connection
 - Special backflow valve with ball in the housing
 - Connection: Rp 2"
- 2 submersible grey water pumps
 - With three-phase current submerged motor pump: 400 V, 50 Hz – type D
 - With alternating current submersible pump: 230 V, 50 Hz – type W
- Degree of protection IP 68
- Double mechanical seal with oil chamber between the seals
- With blockage-free vortex impeller
- 10 m connection cable
- Level switching
 - Pneumatic level switching with 10 m control cables
 - Optionally with air bubble injection to increase operating reliability if installed downstream of a grease separator (accessory)
- Control
 - Degree of protection IP 54
 - 1.5 m cable and CEE plug (16 A) – type D
 - 1.5 m cable and plug with earthing contact (16 A) – type W
 - Isolated group alarm and operation signal
- Tested to EN 12050-2

Order information

Type	Motor rating		Characteristic data			Free passage	Usable volume			Total volume	Weight	Article No.
	P1	P2	Current consumption	Voltage	Speed		Inlet height Z1	Inlet height Z2	Inlet from above			
	[kW]	[kW]	[A]	[V]	[rpm]	[mm]	[l]	[l]	[l]	[l]	[kg]	
Muli-Mini DDP 1.1	0.7	0.55	1.3	400	2900	38	55	100	130	195	66	1206.00.01
Muli-Mini DDP 1.2	1.5	1.1	2.6	400	2900	38	55	100	130	195	74	1206.00.02
Muli-Mini DWP 1.1	0.8	0.55	3.6	230	2900	38	55	100	130	195	66	1206.00.03
Muli-Mini DWP 1.2	1.8	1.1	8.2	230	2900	38	55	100	130	195	74	1206.00.04

Dimensional drawing

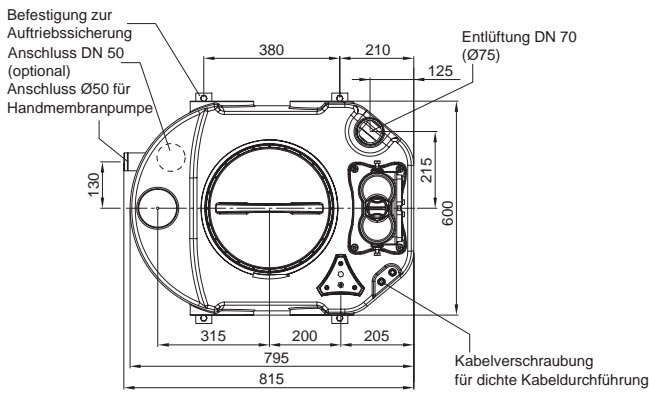
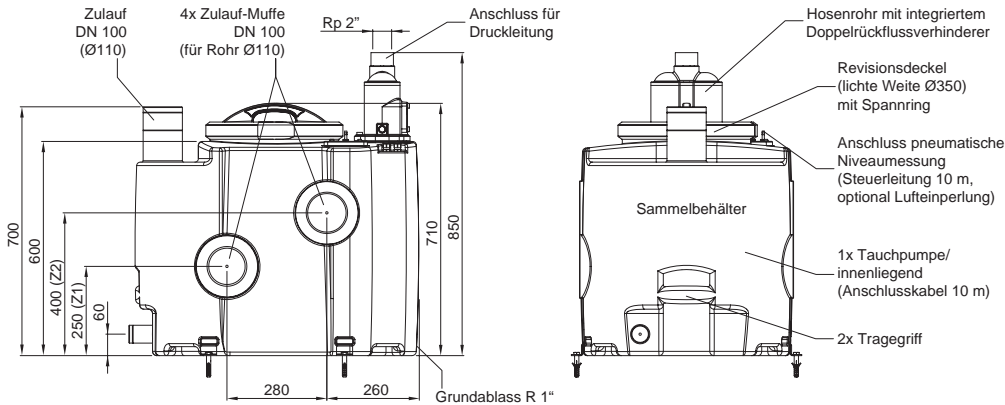

Performance parameters

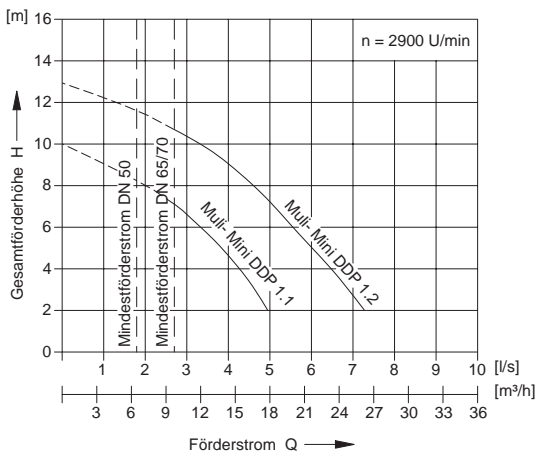

Type	Delivery head [m]	Delivery flow Q at total delivery head H						Delivery media temperature	
		2 m [l/s]	4 m [l/s]	6 m [l/s]	8 m [l/s]	10 m [l/s]	12 m [l/s]	Normal [°C]	Maximum [°C]
Multi-Mini DDP 1.1	2 – 8.2	4.9	4.3	3.2	2.0	–	–	40	65
Multi-Mini DDP 1.2	2 – 11.6	7.2	6.4	5.5	4.6	3.4	1.5	40	65
Multi-Mini DWP 1.1	2 – 8.2	4.9	4.3	3.2	2.0	–	–	40	65
Multi-Mini DWP 1.2	2 – 11.6	7.2	6.4	5.5	4.6	3.4	1.5	40	65

ACO Multi-Star DDP wastewater lifting plant for faecal wastewater – for freestanding installation



Product advantages

- Low weight
- Different inlet heights
- CFD-optimised impeller
- Ready to connect
- High usable volume – up to 185 l
- Adapted to door dimension: 780 mm

Suitable for:

- Grey and black water
- Use downstream of grease separators up to NS 15

Product information

- Areas of use
 - Downstream of grease separators up to NS 15
 - Multiple dwelling units
 - Office buildings, hotels
 - hospitals, Areas of use
- Tank made of polyethylene
 - Bottom outlet R 1"
 - Inspection opening for easy maintenance, diameter: 130 mm (DDP1), 130 mm and 250 mm (DDP2)
 - Connection for manual diaphragm pump DN 50
 - 2 horizontal inlet sockets DN 100
 - 4 horizontal inlet sockets DN 150
 - 2 vertical inlet sockets DN 100/DN 150/DN 200
 - 1 ventilation socket DN 70 (optional DN 100)
- Delivery line connection
 - Special backflow valve with ball in the housing
 - Special adapter DN 80 for elastic connection of the pressure line with 108 – 114.3 mm pipe outside diameter (optional 88 – 90 mm)
 - Connecting flange for stop valve DN 80 PN 16
 - 3-phase motor: 400V, 50Hz
 - Degree of protection IP 68
 - Blockage-free free flow impeller
 - 10 m connection cable
- Level switching
 - Pneumatic level switching with 10 m control cable
 - Optionally with air bubble injection (accessory)
- Control
 - Degree of protection IP 54
 - 1.5 m cable and CEE plug (32 A)
- Isolated group alarm and operation signal
- Tested to EN 12050-1

Order information

Type	Motor rating		Characteristic data			Free passage	Usable volume			Total volume	Weight	Article No.
	P1	P2	Current consumption	Voltage	Speed		Inlet height Z1	Inlet height Z2	Inlet from above			
	[kW]	[kW]	[A]	[V]	[rpm]	[mm]	[l]	[l]	[l]	[kg]		
Muli-Star DDP 1.1	1.83	1.5	5	400	1400	65	65	110	110	150	66	1202.00.01
Muli-Star DDP 1.2	3.45	3	10	400	2800	65	65	110	110	150	74	1202.00.02
Muli-Star DDP 2.1	1.83	1.5	5	400	1400	65	95	185	185	300	66	1202.00.04
Muli-Star DDP 2.2	3.45	3	10	400	2800	65	95	185	185	300	74	1202.00.05

Dimensional drawing

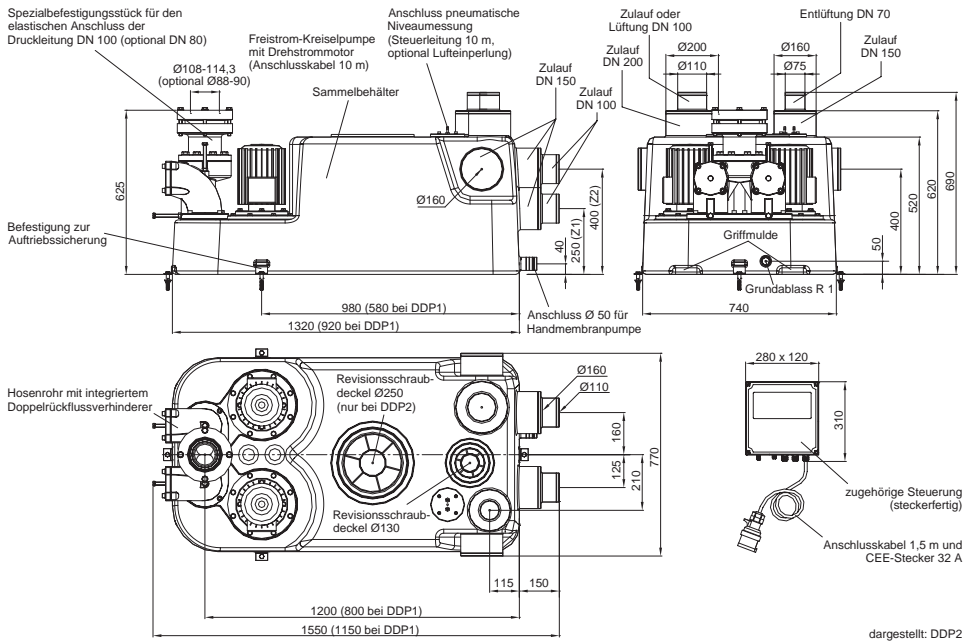

Performance parameters

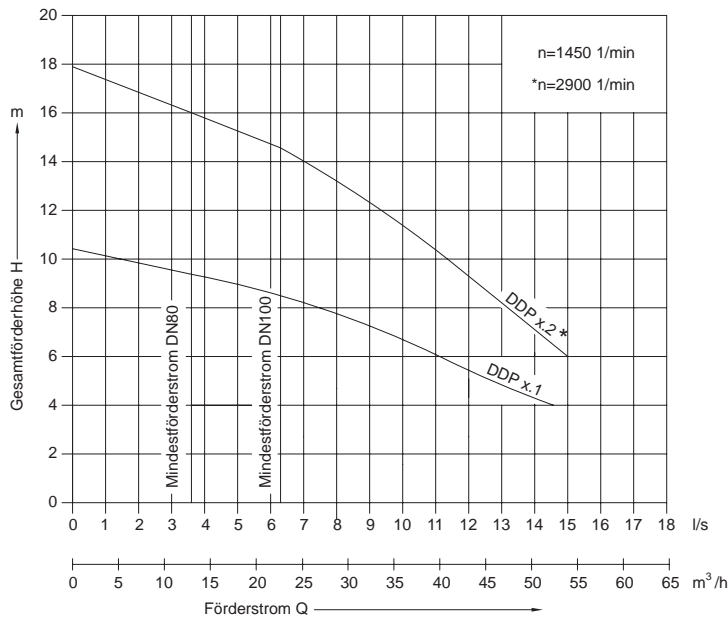

Type	delivery head [m]	Delivery flow Q at total delivery head H							Delivery media temperature	
		4 m [l/s]	6 m [l/s]	8 m [l/s]	10 m [l/s]	12 m [l/s]	14 m [l/s]	16 m [l/s]	Normal [°C]	Maximum [°C]
Muli-Star DDP 1.1	4 – 9.5	14.44	11.0	7.5	1.5	–	–	–	40	65
Muli-Star DDP 1.2	6 – 16	–	15.0	13.3	11.38	9.4	7.1	3.51	40	65
Muli-Star DDP 2.1	4 – 9.5	14.44	11.0	7.5	1.5	–	–	–	40	65
Muli-Star DDP 2.2	6 – 16	–	15.0	13.3	11.38	9.4	7.1	3.51	40	65

Wastewater lifting plants

ACO Multi-PE-S duo wastewater lifting plant for faecal wastewater – for freestanding installation



Product advantages

- Wastewater lifting plant with submersible pump and grinder
- Different inlet heights
- Lower costs due to small pressure line cross-section

Suitable for:

- Grey and black water
- Not for use downstream of grease separators

Product information

- Areas of use
 - Renovation of old buildings
 - Where long pressure line to the sewer
 - Properties in which liquids with solid or fibrous substances occur, e.g. laundries
- Tank made of polyethylene
 - With drain plug
 - With connection for manual diaphragm pump R 1½"
 - With 2 horizontal inlet sockets DN 100/DN 150
 - With 1 vertical inlet socket with step DN 100/DN 150
 - With ventilation socket DN 100
- Delivery line connection
 - With 2 ball backflow stops R 2"
 - With 2 stop valves R 2"
 - Y-branch pipe R 2", made of stainless steel
- 2 pump units
 - Motor 400 V, 50 Hz
 - Degree of protection IP 68
- Pneumatic switching with pneumatic pipe and pneumatic control line
- Switching and warning device
 - Degree of protection IP 54
 - With 1.5 m cable and CEE plug
 - With isolated group alarm and operation signal
 - Incl. 4 m pneumatic control line between lifting plant and switchbox
- Tested to EN 12050-1

Order information

Type	Motor rating		Characteristic data			Usable volume			Total volume	Weight	Article No.
	P1	P2	Current consumption	Voltage	Speed	Inlet height Z1	Inlet height Z2	Inlet from above			
	[kW]	[kW]	[A]	[V]	[rpm]	[l]	[l]	[l]	[l]	[kg]	
Muli-PE-S-100 duo	1.2	0.9	2.3	400	2900	40	60	60	105	180	0159.04.24
Muli-PE-S-200 duo	2.5	1.7	4.1	400	2900	40	60	60	105	185	0175.02.67

Dimensional drawing

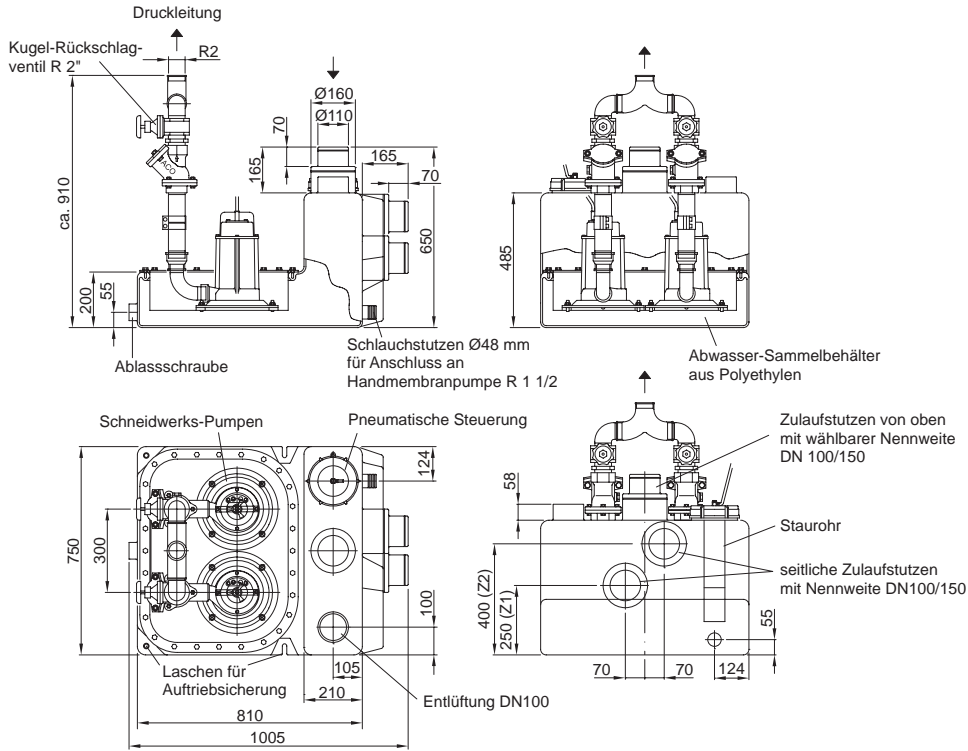

Performance parameters

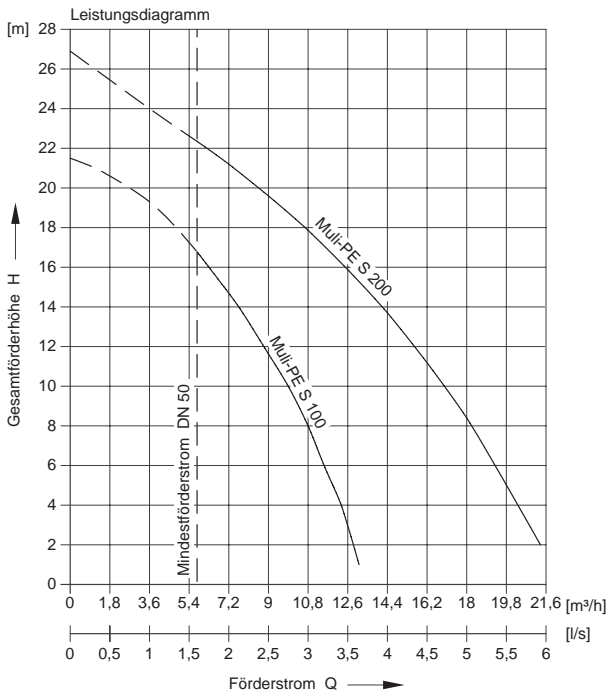

Type	delivery head [m]	Delivery flow Q at total delivery head H												Delivery media temperature	
		2 m [l/s]	4 m [l/s]	6 m [l/s]	8 m [l/s]	10 m [l/s]	12 m [l/s]	14 m [l/s]	16 m [l/s]	18 m [l/s]	20 m [l/s]	22 m [l/s]	24 m [l/s]	Normal [°C]	Maximum [°C]
Muli-PE-S-100 duo	2 – 18	3.57	3.4	3.2	3.0	2.75	2.43	2.1	1.75	1.3	–	–	–	40	60
Muli-PE-S-200 duo	2 – 24	5.93	5.65	5.36	5.05	4.72	4.34	3.94	3.47	2.96	2.38	1.73	1.2	40	60

ACO Muli Pro-PE K duo wastewater lifting plant for faecal wastewater – for freestanding installation



Product advantages

- Large usable tank volume
- Different inlet heights
- High operational safety due to pneumatic pipe and air bubble injection
- Suitable for greasy wastewater
- Energy saving channel impeller pump
- Adapted to door dimension: 780 mm

Suitable for:

- Grey and black water
- Use downstream of grease separators up to NS 20

Product information

- Areas of use
 - Multiple dwelling units
 - Smaller commercial properties with large quantities of wastewater
 - Downstream of grease separators up to NS 20
 - For long pressure line sections with large level differences
- Tank made of polyethylene
 - With drain plug
 - With connection for manual diaphragm pump R 1½"
 - With 4 horizontal inlet sockets DN 150
 - With 1 vertical inlet socket DN 150
 - With 1 inspection opening, clear width: 320 mm
 - With ventilation socket DN 100
- Delivery line connection
 - With 2 special backflow valves DN 80 (DN 100 for Muli Pro-PE K-75 duo) with backwash device
 - With Y-branch pipe
 - With special adapter DN 100 for connection of the pressure line with 108 – 114.3 mm pipe outside diameter
- 2 pump units
 - Motor 400 V, 50 Hz
 - Degree of protection IP 68
 - With channel impeller
- Pneumatic level switching with pneumatic pipe and pneumatic control line
- Incl. mini compressor for air bubble injection
- Switching and warning device
 - Degree of protection IP 54
 - With 1.5 m cable and CEE plug
 - With isolated group alarm and operation signal
 - Incl. 7 m cable between lifting plant and switchbox
- Tested to EN 12050-1
- K-55/K-75: control box with smooth start & stop

Order information

Type	Motor capacity		Characteristic data			Free passage	Usable volume				Total volume	Weight	Article No.
	P1	P2	Current consumption	Voltage	Speed		Inlet height Z1	Inlet height Z2	Inlet height Z3	Inlet from above			
	[kW]	[kW]	[A]	[V]	[rpm]	[mm]	[m]	[m]	[m]	[m]	[m³]	[kg]	
Muli Pro-PE K-15 duo	2.01	1.5	3.6	400	1450	70	240	305	330	330	520	295	0175.13.17
Muli Pro-PE K-22 duo	2.94	2.2	5.2	400	1450	70	240	305	330	330	520	310	0175.13.18
Muli Pro-PE K-30 duo	3.87	3	6.6	400	1450	70	240	305	330	330	520	350	0175.13.19
Muli Pro-PE K-55 duo	6.71	5.5	11.6	400	1450	70	240	305	330	330	520	425	0175.13.20
Muli Pro-PE K-75 duo	8.97	7.5	15.5	400	1450	100	240	305	330	330	520	495	0175.13.21

Dimensional drawing

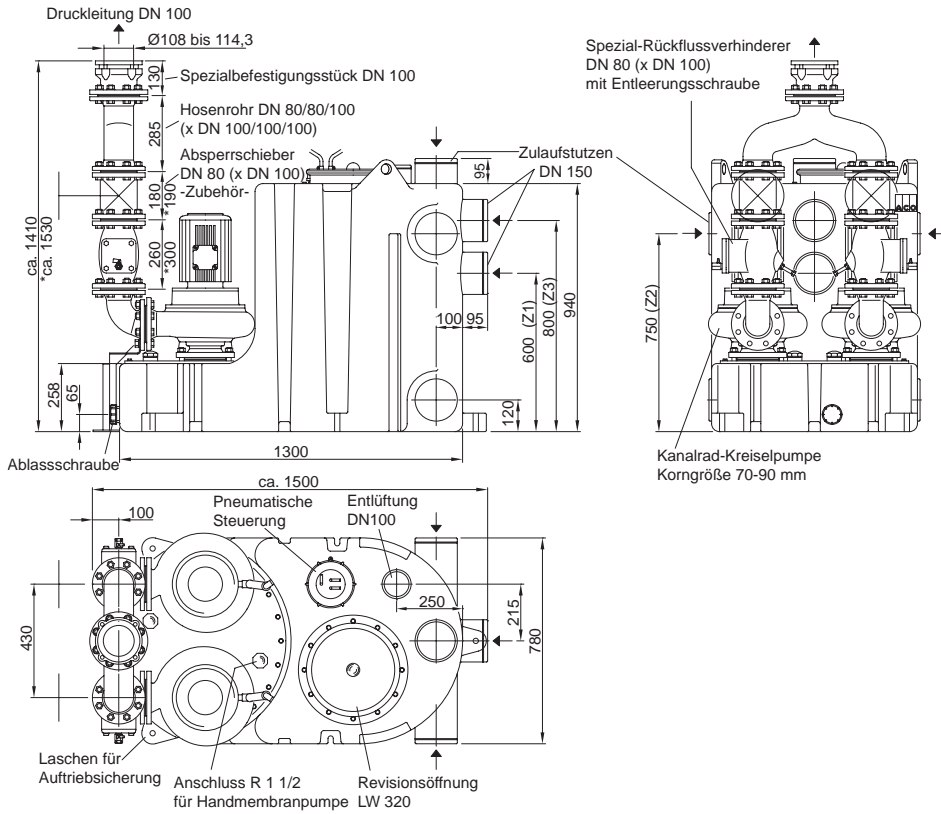

Performance parameters

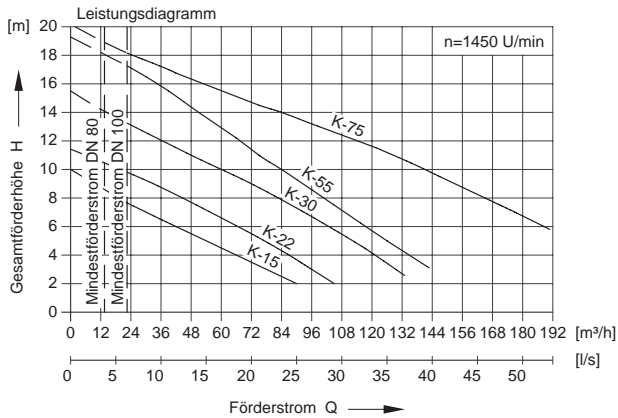

Type	Delivery head [m]	Delivery flow Q at total delivery head H								Delivery media temperature	
		4 m [l/s]	6 m [l/s]	8 m [l/s]	10 m [l/s]	12 m [l/s]	14 m [l/s]	16 m [l/s]	18 m [l/s]	Normal [°C]	Maximum [°C]
Muli Pro-PE K-15 duo	3 – 8	18.3	11.7	5.8	–	–	–	–	–	40	60
Muli Pro-PE K-22 duo	3 – 10	24.2	18.5	12.5	5.3	–	–	–	–	40	60
Muli Pro-PE K-30 duo	4 – 14	33.5	28.4	23.1	16.8	10.3	4.2	–	–	40	60
Muli Pro-PE K-55 duo	4 – 17	37.3	32.7	28.1	23.1	18.8	14.1	9.4	–	40	60
Muli Pro-PE K-75 duo	6 – 18	–	51.8	46.2	39.2	31.7	23.2	14.2	6.8	40	60

ACO Muli Pro-PE V duo wastewater lifting plant for faecal wastewater – for freestanding installation



Product advantages

- Large usable tank volume
- Different inlet heights
- High operational safety due to pneumatic pipe and air bubble injection
- Suitable for greasy wastewater
- Blockage-free free flow impeller
- Adapted to door dimension: 780 mm

Suitable for:

- Grey and black water
- Use downstream of grease separators up to NS 15

Product information

- Areas of use
 - Multiple dwelling units
 - Smaller commercial properties with large quantities of wastewater
 - For wastewater with long-fibre solids
 - Downstream of grease separators up to NS 15
- Tank made of polyethylene
 - With drain plug
 - With connection for manual diaphragm pump R 1½"
 - With 4 horizontal inlet sockets DN 150
 - With 1 vertical inlet socket DN 150
 - With 1 inspection opening, clear width: 320 mm
 - With ventilation socket DN 100
- Delivery line connection
 - With 2 special backflow valves DN 80 with backwash device
 - With Y-branch pipe
 - With special adapter DN 100 for connection of the pressure line with 108 – 114.3 mm pipe outside diameter
- 2 pump units
 - Motor 400 V, 50 Hz
 - Degree of protection IP 68
 - With vortex impeller
- Pneumatic level switching with pneumatic pipe and pneumatic control line
- Mini compressor for air bubble injection
- Switching and warning device
 - Degree of protection IP 54
 - With 1.5 m cable and CEE plug
 - With isolated group alarm and operation signal
 - Incl. 4 m cable between lifting plant and switchbox
- Tested to EN 12050-1

Order information

Type	Motor rating		Characteristic data			Free passage	Usable volume				Total volume	Weight	Article No.
	P1	P2	Current consumption	Voltage	Speed		Inlet height Z1	Inlet height Z2	Inlet height Z3	Inlet from above			
	[kW]	[kW]	[A]	[V]	[rpm]	[mm]	[m]	[m]	[m]	[m]	[m³]	[kg]	
Muli Pro-PE V-15 duo	2.01	1.5	4.1	400	1450	80	240	305	330	330	520	210	0175.12.89
Muli Pro-PE V-22 duo	2.94	2.2	5.2	400	3000	80	240	305	330	330	520	215	0175.12.90
Muli Pro-PE V-30 duo	3.87	3	7.2	400	3000	80	240	305	330	330	520	225	0175.12.91
Muli Pro-PE V-40 duo	5.1	4	10.3	400	3000	80	240	305	330	330	520	230	0175.12.92

Dimensional drawing

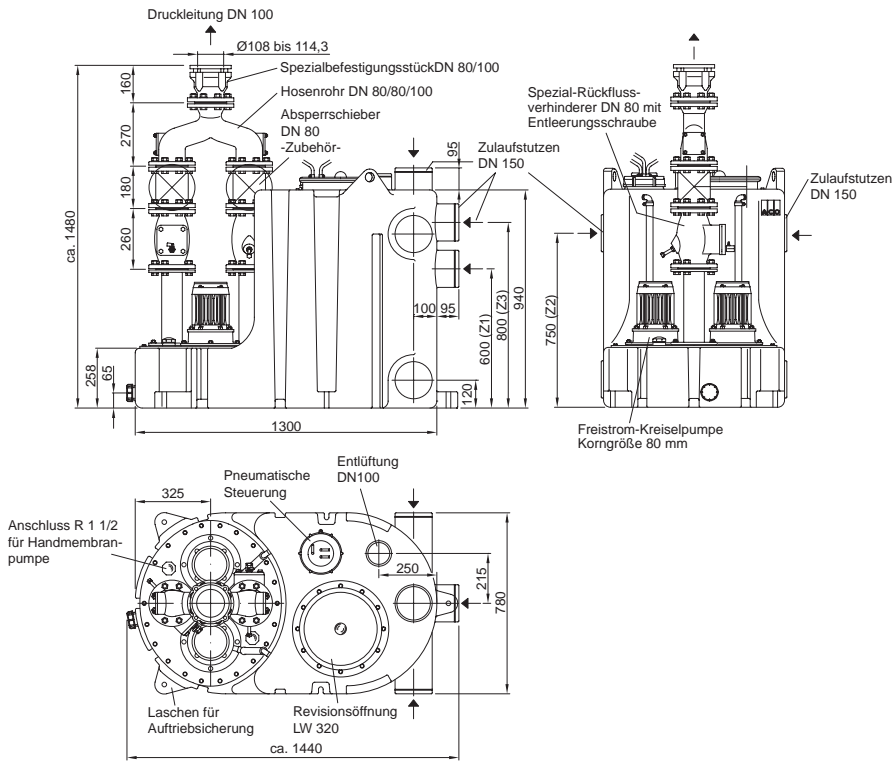

Performance parameters

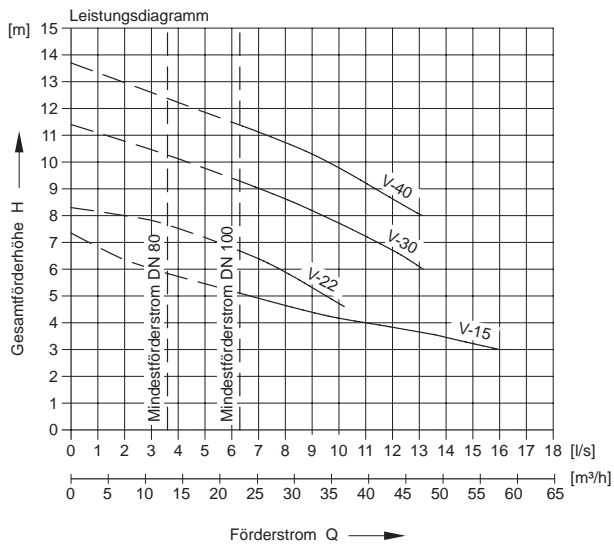

Type	Delivery head [m]	Delivery flow Q at total delivery head H					Delivery media temperature	
		4 m [l/s]	6 m [l/s]	8 m [l/s]	10 m [l/s]	12 m [l/s]	Normal [°C]	Maximum [°C]
Muli Pro-PE V-15 duo	3 – 6	11.0	3.1	–	–	–	40	60
Muli Pro-PE V-22 duo	5 – 7	–	7.8	–	–	–	40	60
Muli Pro-PE V-30 duo	6 – 10	–	13.15	9.4	4.35	–	40	60
Muli Pro-PE V-40 duo	8 – 12	–	–	13.1	9.6	4.7	40	60

ACO Muli Pro-PE K Parallel wastewater lifting plant for faecal wastewater – for freestanding installation



Product advantages

- Large usable tank volume
- Different inlet heights
- High operational safety due to pneumatic pipe and air bubble injection
- Energy saving channel impeller pump
- Adapted to door dimension: 780 mm
- Can be brought in separately

Suitable for:

- Grey and black water
- Use downstream of grease separators up to NS 20

Product information

- Areas of use
 - Commercial or industrial properties with large quantities of wastewater
 - For long pressure line sections with large level differences
- Tank made of polyethylene
 - With drain plug
 - With connection for manual diaphragm pump R 1½"
 - With 6 horizontal inlet sockets DN 150
 - With 2 vertical inlet socket DN 150
 - With 2 inspection openings, clear width: 320 mm
 - With ventilation socket DN 100
- Delivery line connection
 - With 2 special backflow valves DN 80 (DN 100 for Muli Pro-PE K-75 Parallel) with backwash device
 - With Y-branch pipe
 - With special adapter DN 100 for connection of the pressure line with 108 – 114.3 mm pipe outside diameter
- 2 pump units
 - Motor 400 V, 50 Hz
 - Degree of protection IP 68
 - With channel impeller
- Pneumatic level switching with pneumatic pipe and pneumatic control line
- Mini compressor for air bubble injection
- Switching and warning device
 - Degree of protection IP 54
 - With 1.5 m cable and CEE plug
 - With isolated group alarm and operation signal
 - Incl. 7 m cable between lifting plant and switchbox
- Tested to EN 12050-1
- K-55/K-75: control box with smooth start & stop

Order information

Type	Motor rating		Characteristic data			Free passage	Usable volume				Total volume	Weight	Article No.
	P1	P2	Current consumption	Voltage	Speed		Inlet height Z1	Inlet height Z2	Inlet height Z3	Inlet from above			
	[kW]	[kW]	[A]	[V]	[rpm]	[mm]	[m]	[m]	[m]	[m]	[l]	[kg]	
Muli Pro-PE K-15 parallel	2.01	1.5	3.6	400	1450	70	480	610	660	660	1040	315	0175.13.23
Muli Pro-PE K-22 parallel	2.94	2.2	5.2	400	1450	70	480	610	660	660	1040	325	0175.13.24
Muli Pro-PE K-30 parallel	3.87	3	6.6	400	1450	70	480	610	660	660	1040	420	0175.13.25
Muli Pro-PE K-55 parallel	6.71	5.5	11.6	400	1450	70	480	610	660	660	1040	465	0175.13.26
Muli Pro-PE K-75 parallel	8.97	7.5	15.5	400	1450	70	480	610	660	660	1040	510	0175.13.27

Dimensional drawing

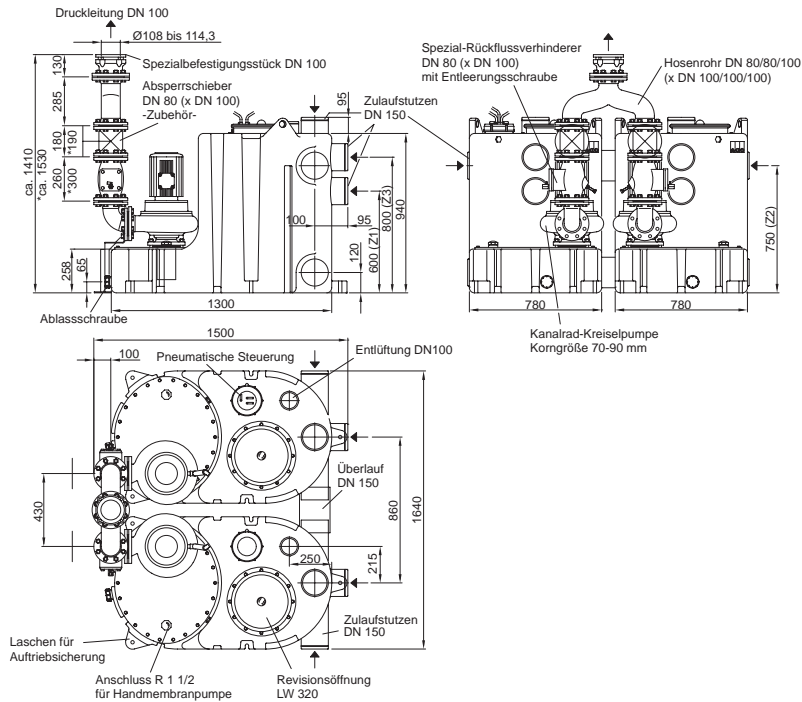

Performance parameters

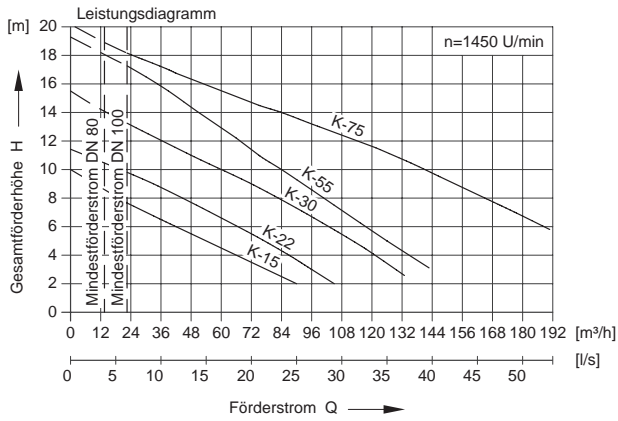

Type	Delivery head [m]	Delivery flow Q at total delivery head H								Delivery media temperature	
		4 m [l/s]	6 m [l/s]	8 m [l/s]	10 m [l/s]	12 m [l/s]	14 m [l/s]	16 m [l/s]	18 m [l/s]	Normal [°C]	Maximum [°C]
Muli Pro-PE K-15 parallel	3 – 8	18.3	11.7	5.8	–	–	–	–	–	40	60
Muli Pro-PE K-22 parallel	3 – 10	24.2	18.5	12.5	5.3	–	–	–	–	40	60
Muli Pro-PE K-30 parallel	4 – 14	33.5	28.4	23.1	16.8	10.3	4.2	–	–	40	60
Muli Pro-PE K-55 parallel	4 – 17	37.3	32.7	28.1	23.1	18.8	14.1	9.4	–	40	60
Muli Pro-PE K-75 parallel	6 – 18	–	51.8	46.2	39.2	31.7	23.2	14.2	6.8	40	60

ACO Muli Pro-PE V Parallel wastewater lifting plant for faecal wastewater – for freestanding installation



Product advantages

- Large usable tank volume
- Different inlet heights
- High operational safety due to pneumatic pipe and air bubble injection
- Blockage-free free flow impeller
- Adapted to door dimension: 780 mm
- Can be brought in separately

Suitable for:

- Grey and black water
- Use downstream of grease separators up to NS 20

Product information

- Areas of use
 - Commercial or industrial properties with large quantities of wastewater
 - Multiple dwelling units
 - Downstream of grease separators up to NS 20
 - For wastewater with long-fibre solids
- Tank made of polyethylene
 - With drain plug
 - With connection for manual diaphragm pump R 1½"
 - With 6 horizontal inlet sockets DN 150
 - With 2 vertical inlet socket DN 150
 - With 2 inspection openings, clear width: 320 mm
 - With ventilation socket DN 100
- Delivery line connection
 - With 2 special backflow valves DN 80 with backwash device
 - With Y-branch pipe
 - With special adapter DN 100 for connection of the pressure line with 108 – 114.3 mm pipe outside diameter
- 2 pump units
 - Motor 400 V, 50 Hz
 - Degree of protection IP 68
 - With blockage-free vortex impeller
- Pneumatic level switching with pneumatic pipe and pneumatic control line
- Mini compressor for air bubble injection
- Switching and warning device
 - Degree of protection IP 54
 - With 1.5 m cable and CEE plug
 - With isolated group alarm and operation signal
 - Incl. 4 m cable between lifting plant and switchbox
- Tested to EN 12050-1

Order information

Type	Motor capacity		Characteristic data			Free passage	Usable volume				Total volume	Weight	Article No.
	P1	P2	Current consumption	Voltage	Speed		Inlet height Z1	Inlet height Z2	Inlet height Z3	Inlet from above			
	[kW]	[kW]	[A]	[V]	[rpm]	[mm]	[m]	[m]	[m]	[m]	[l]	[kg]	
Muli Pro-PE V-15 parallel	2.01	1.5	4.1	400	1450	80	480	610	660	660	1040	210	0175.12.94
Muli Pro-PE V-22 parallel	2.94	2.2	5.2	400	3000	80	480	610	660	660	1040	215	0175.12.95
Muli Pro-PE V-30 parallel	3.87	3	7.2	400	3000	80	480	610	660	660	1040	225	0175.12.96
Muli Pro-PE V-40 parallel	5.1	4	10.3	400	3000	80	480	610	660	660	1040	230	0175.12.97



Dimensional drawing

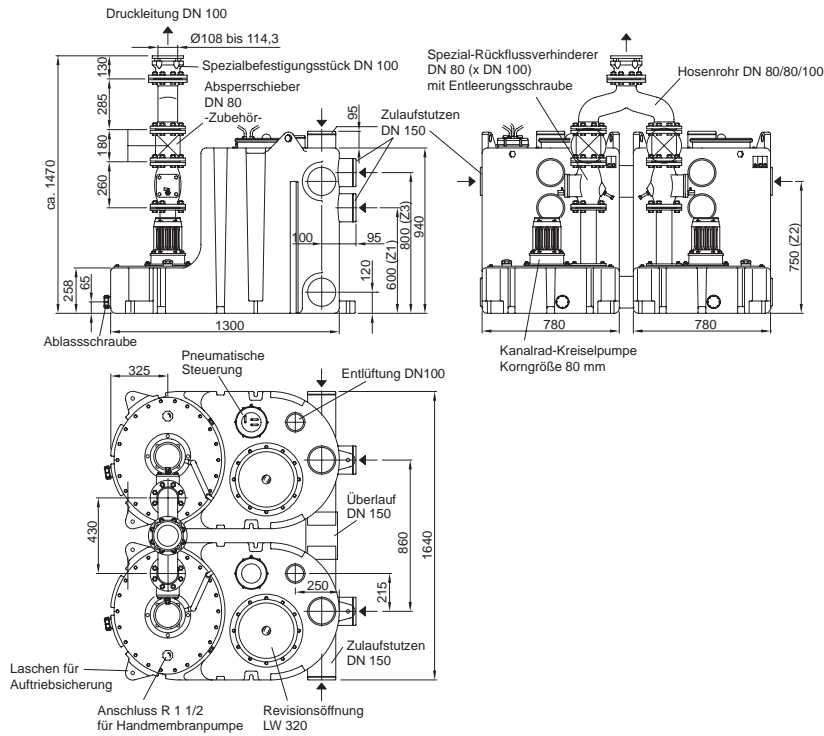

Performance parameters

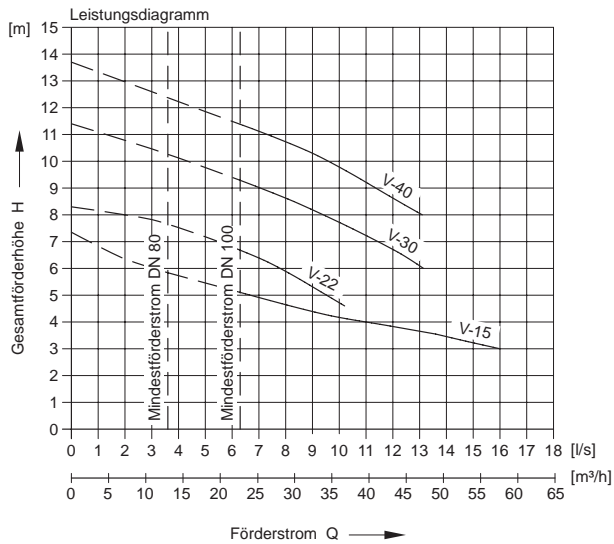

Type	Delivery head [m]	Delivery flow Q at total delivery head H					Delivery media temperature	
		4 m [l/s]	6 m [l/s]	8 m [l/s]	10 m [l/s]	12 m [l/s]	Normal [°C]	Maximum [°C]
Muli Pro-PE V-15 parallel	3 – 6	11.0	3.1	–	–	–	40	60
Muli Pro-PE V-22 parallel	5 – 7	–	7.8	–	–	–	40	60
Muli Pro-PE V-30 parallel	6 – 10	–	13.15	9.4	4.35	–	40	60
Muli Pro-PE V-40 parallel	8 – 12	–	–	13.1	9.6	4.7	40	60

Wastewater lifting plants

ACO Muli Pro 1.x VA duo wastewater lifting plant for faecal wastewater – for freestanding installation



Product advantages

- Suitable for greasy wastewater
- High operational safety due to pneumatic pipe and air bubble injection
- Blockage-free free flow impeller

Suitable for:

- Grey and black water
- Use downstream of grease separators up to NS 10

Product information

- Areas of use
 - Multiple dwelling units
 - Smaller commercial properties with large quantities of wastewater
 - Wastewater with long-fibre solids
 - Downstream of grease separators up to NS 10
- Tank made of stainless steel, material 1.4571 AISI 314
 - With drain plug
 - With connection for manual diaphragm pump R 1½"
 - Optional inspection opening or inlet socket
 - With 2 inspection openings, diameter: 285 mm or with horizontal inlet socket DN 100/DN 150
 - With ventilation connection DN 100 for connection to plastic pipe
- Delivery line connection
 - Via 2 special backflow valves DN 80 with backwash device
 - With Y-branch pipe
 - With special integrated adapter DN 100 for connection of the delivery line with 108 – 114.3 mm pipe outside diameter
- 2 pump units
 - Motor 400 V, 50 Hz
 - Degree of protection IP 68
 - With vortex impeller
- Pneumatic level switching with pneumatic pipe and pneumatic control line
- Mini compressor for air bubble injection
- Switching and warning device
 - Degree of protection IP 54
 - With 1.5 m cable and CEE plug
 - With isolated group alarm and operation signal
 - Incl. 4 m cable between lifting plant and switchbox
- Tested to EN 12050-1

Order information

Type	Motor rating		Characteristic data		Free passage	Usable volume	Total volume	Weight	Article No.
	P1	P2	Current consumption	Voltage					
	[kW]	[kW]	[A]	[V]	[mm]	[l]	[l]	[kg]	
Muli Pro 1.1VA duo	2.01	1.5	4.1	400	80	155	270	210	0175.06.69
Muli Pro 1.2 VA duo	2.94	2.2	5.2	400	80	155	270	215	0175.06.70
Muli Pro 1.3 VA duo	3.87	3	7.2	400	80	155	270	225	0175.06.71
Muli Pro 1.4 VA duo	5.1	4	10.3	400	80	155	270	230	0175.06.72

Dimensional drawing

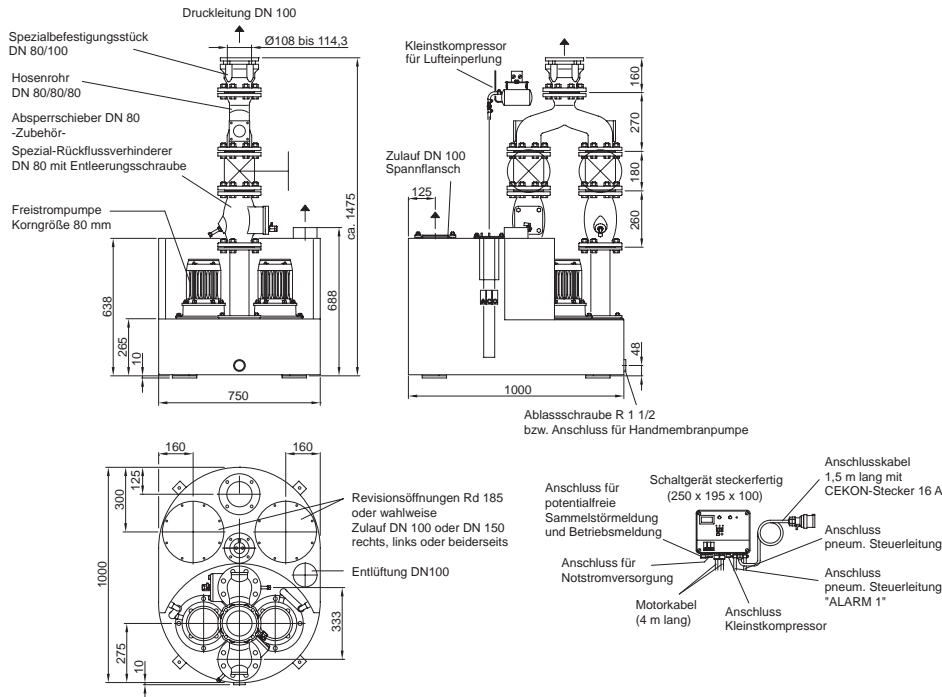

Performance parameters

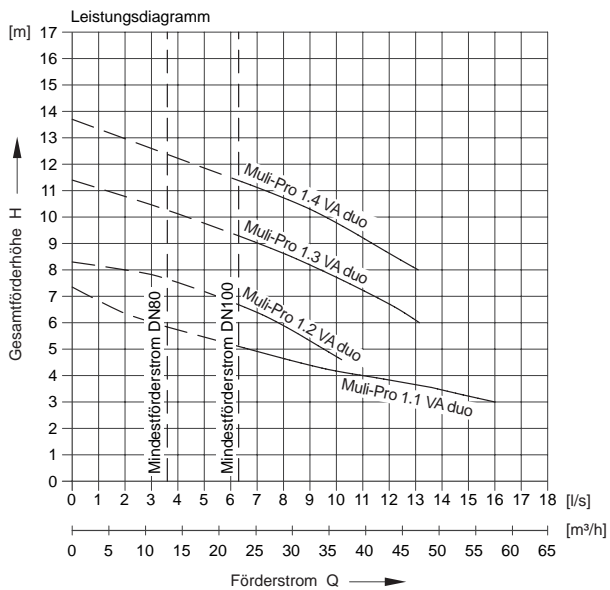

Type	Delivery head [m]	Delivery flow Q at total delivery head H					Delivery media temperature	
		4 m [l/s]	6 m [l/s]	8 m [l/s]	10 m [l/s]	12 m [l/s]	Normal [°C]	Maximum [°C]
Muli Pro 1.1 VA duo	3 – 6	11.0	3.1	–	–	–	40	60*
Muli Pro 1.2 VA duo	5 – 7	–	7.8	–	–	–	40	60*
Muli Pro 1.3 VA duo	6 – 10	–	13.15	9.4	4.35	–	40	60*
Muli Pro 1.4 VA duo	8 – 12	–	–	13.1	9.6	4.7	40	60*

* Higher temperatures on request

ACO Muli Pro 2.x VA duo wastewater lifting plant for faecal wastewater – for freestanding installation



Product advantages

- Suitable for greasy wastewater
- High operational safety due to pneumatic pipe and air bubble injection
- Blockage-free free flow impeller

Suitable for:

- Grey and black water
- Use downstream of grease separators up to NS 10

Product information

- Areas of use
 - Multiple dwelling units
 - Downstream of grease separators up to NS 10
 - For municipal and industrial wastewater
- Tank made of stainless steel, material 1.4571
 - With drain plug
 - With connection for manual diaphragm pump R 1½"
 - Optional inspection opening or inlet socket
 - With 2 inspection openings, diameter: 285 mm or with horizontal inlet socket DN 100/DN 150
 - With ventilation connection DN 100 for connection to plastic pipe
- Delivery line connection
 - Via 2 special backflow valves DN 80 with backwash device
 - With special integrated adapter DN 100 for connection of the delivery line with 108 – 114.3 mm pipe outside diameter
- 2 pump units
 - Motor 400 V, 50 Hz
 - Degree of protection IP 68
 - With vortex impeller
- Pneumatic level switching with pneumatic pipe and pneumatic control line
- Mini compressor for air bubble injection
- Switching and warning device
 - Degree of protection IP 54
 - With 1.5 m cable and CEE plug
 - With isolated group alarm and operation signal
 - Incl. 4 m cable between lifting plant and switchbox
- Tested to EN 12050-1

Order information

Type	Motor rating		Characteristic data		Free passage	Usable volume		Total volume	Weight	Article No.
	P1	P2	Current consumption	Voltage		Inlet height Z1	Inlet from above			
	[kW]	[kW]	[A]	[V]	[mm]	[m]	[m]	[l]	[kg]	
Muli Pro 2.1 VA duo	2.01	1.5	4.1	400	80	185	245	365	290	0175.06.74
Muli Pro 2.2 VA duo	2.94	2.2	5.2	400	80	185	245	365	295	0175.06.75
Muli Pro 2.3 VA duo	3.87	3	7.2	400	80	185	245	365	305	0175.06.76
Muli Pro 2.4 VA duo	5.1	4	10.3	400	80	185	245	365	310	0175.06.77

Dimensional drawing

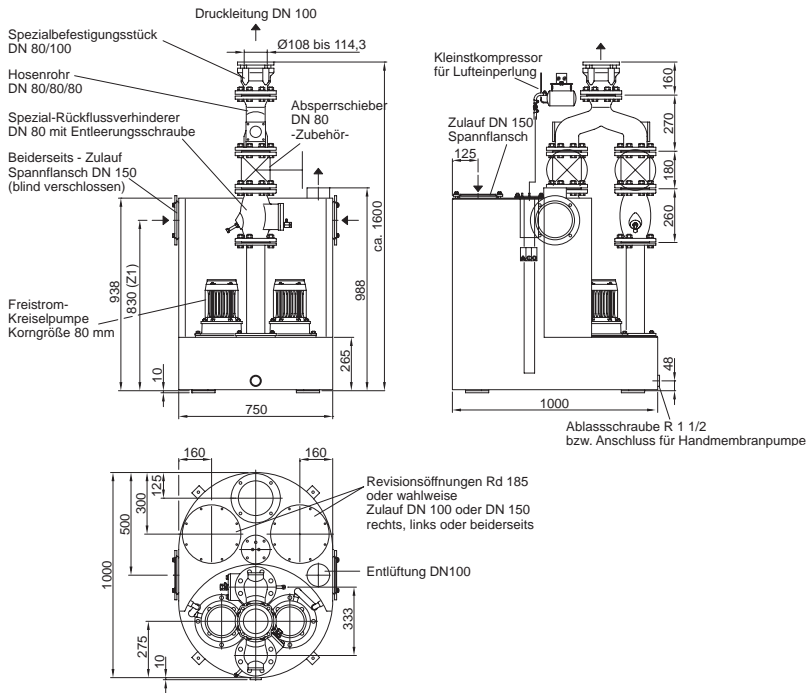

Performance parameters

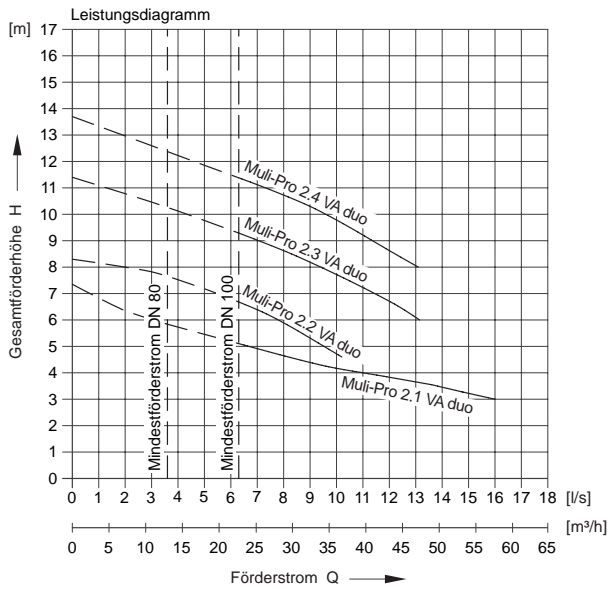

Type	Delivery head [m]	Delivery flow Q at total delivery head H					Delivery media temperature	
		4 m [l/s]	6 m [l/s]	8 m [l/s]	10 m [l/s]	12 m [l/s]	Normal [°C]	Maximum [°C]
Muli Pro 2.1 VA duo	3 – 6	11.0	3.1	–	–	–	40	60*
Muli Pro 2.2 VA duo	5 – 7	–	7.8	–	–	–	40	60*
Muli Pro 2.3 VA duo	6 – 10	–	13.15	9.4	4.35	–	40	60*
Muli Pro 2.4 VA duo	8 – 12	–	–	13.1	9.6	4.7	40	60*

* Higher temperatures on request

Muli Pro-PE N XL duo wastewater lifting plant for faecal wastewater – for freestanding installation

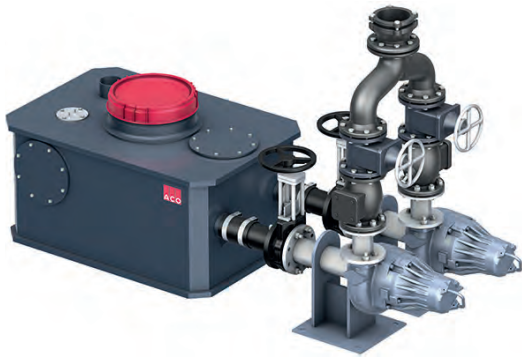

Product advantages

- Tank can be configured individually to the customer's wishes
- High degree of operating reliability and fail-safe function
- Pump with adaptive impeller for low-blockage operation
- Large usable tank volume (up to 1100 litre depending on the version)
- Inlet height selectable depending on version
- Adaptive N-impeller

Suitable for:

- Grey and black water
- Use downstream of grease separators up to NS 30

Product information

- Areas of use
 - Commercial or industrial properties with large quantities of wastewater
 - Downstream of grease separators
 - Wastewater containing long and short fibrous substances
 - Multiple dwelling units
- Tank made of PE-HD
 - 1x inspection opening for easy maintenance (350 mm clear width) with odourproof screw cover
 - Fixing set for buoyancy-proof anchorage
 - Inlet optionally horizontal on the side or end faces or vertically from above, optionally in DN 100, DN 150 or DN 200
 - Vertical socket optionally DN 70/DN 100 (ventilation)
 - Bottom outlet R 1½"
- Two horizontally installed pumps
 - 400 V/50 Hz
 - Degree of protection: IP 68
 - Adaptive impeller
 - Cable length: 10 m
- Formation of pressure line
 - Two special backflow valves with backwash device
 - Special adapter DN 100 for connection of the pressure line with 108 – 114 mm pipe outside diameter (optional 88 – 90 mm)
- Pneumatic level switching with pneumatic pipe and pneumatic control line
- Mini compressor with air bubble injection available as an accessory
- Switching and warning device
 - Degree of protection: IP 54
 - Cable and CEE plug (16 A): 1.5 m
 - Isolated group alarm and operation signal
 - Pneumatic control line and motor cable between the lifting plant and switchbox: 10 m

Order information

Type	Description	Motor rating		Characteristic data			Article No.	
		P1	P2	Current consumption	Voltage	Speed		Weight
		[kW]	[kW]	[A]	[V]	[rpm]	[kg]	
Pro-PE N-20 XL	<ul style="list-style-type: none"> ■ Usable volume □ Min: 135 l □ Max: 1135 l 	2.3	2	3.8	400	1460	<ul style="list-style-type: none"> □ Min: 410 kg □ Max: 500 kg 	0175.59.20
Pro-PE N-24 XL	<ul style="list-style-type: none"> ■ Total volume □ Min: 375 l □ Max: 2000 l 	2.8	2.4	5.5	400	1500	<ul style="list-style-type: none"> □ Min: 410 kg □ Max: 500 kg 	0175.59.21
Pro-PE N-47 XL	<ul style="list-style-type: none"> □ Min: 375 l □ Max: 2000 l 	5.6	4.7	10	400	1460	<ul style="list-style-type: none"> □ Min: 600 kg □ Max: 700 kg 	0175.59.22

Dimensional drawing

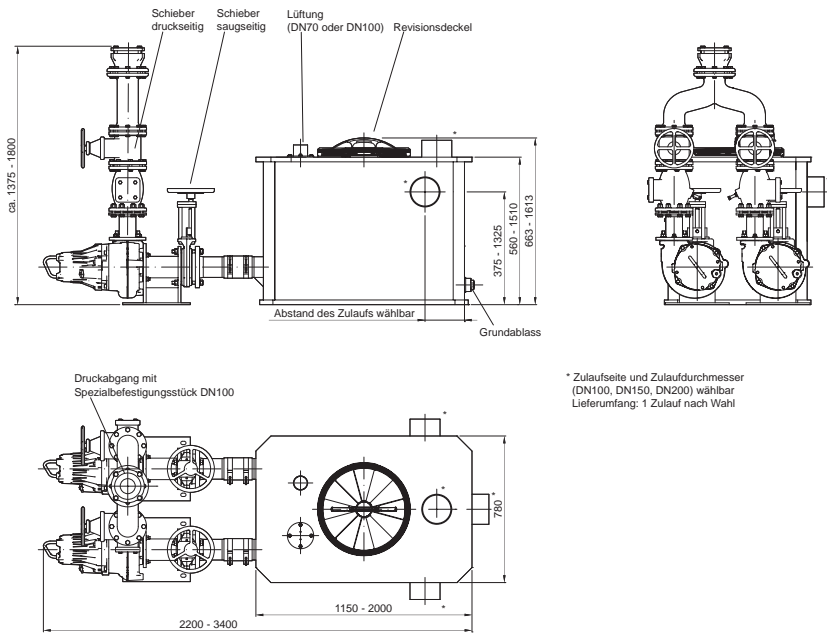

The ACO Muli Pro-PE N XL lifting plant

The new model can be used for faecal, non-faecal and treated wastewater from grease separators. The application areas are commercial or industrial properties which produce very large quantities of wastewater (with both long and short-fibre substances).

The new ACO Muli Pro-PE N XL lifting plant has a range of product advantages on offer. The robust tank made of polyethylene (PE-HD) with large usable volume of up to 1100 l can be delivered with a far larger capacity, individually matched to the customer's wishes. The inlet height (between 375 and 1325 mm depending on the version) and inlet side, like the tank length, is freely selectable. Service friendliness was also a focal point in the development: The pump is installed horizontally. The advantage: Volute casings of vertically installed pumps have to be ventilated so that the pumping operation can start. This is generally done by means of a hose connection which is fed back into the tank. During operation this hose connection can become blocked up by foreign bodies and the pump thus becomes blocked too. In horizontally installed pumps this hose connection is not required, as the pump ventilates itself via the pressure line. Pumps of this type can also be replaced or repaired during on-going operation – thanks to a gate valve in the inlet and discharge side – without having to drain the tank.

Performance parameters

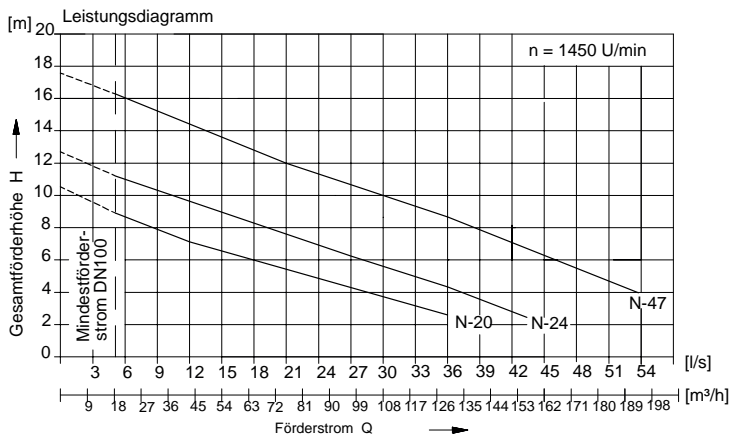

Type	Delivery head [m]	Delivery flow Q at total delivery head H							Delivery media temperature	
		4 m [l/s]	6 m [l/s]	8 m [l/s]	10 m [l/s]	12 m [l/s]	14 m [l/s]	16 m [l/s]	Normal [°C]	Maximum [°C]
Pro-PE N-20 XL	2 – 9	28.5	18.0	8.3	–	–	–	–	40	60*
Pro-PE N-24 XL	2 – 11.2	37.5	28.5	19.4	10.5	–	–	–	40	60*
Pro-PE N-47 XL	2 – 16.4	53.5	46.2	38.7	30.0	21.0	13.5	6.0	40	60*

* larger tanks and pumps possible on request

Wastewater lifting plants

Upstream tank plants

Upstream tanks with eccentric screw pumps are always required if greasy kitchen wastewater has to be pumped or lifted from the "place of production" to the separator. The focus here is clearly on low-turbulence transport; under no circumstances may the dissolved greases be allowed to be mixed with the other wastewater; keyword: Emulsion. The eccentric screw pump belongs to the group of displacement pumps. Its main components are the rotating rotor, the stator, the gearbox and the drive motor. This pump type is not comparable with standard wastewater pumps and has several special features. One of these special features is the uniform pressure and flow rate generated with each rotation of the rotor. If the pressure line is shut off due to ignorance or become blocked

during operation, the pumps continue to pump until a pipe or connection bursts. Restriction of the pump by backpressure, as in a comparable centrifugal pump, does not occur here. Furthermore, displacement pumps are usually self-priming, the medium can be drawn through the pump at a higher level. This enables very variable special solutions, e.g. installation of pumps mounted separately on the wall and the tank in a shaft. Sensors in the winding of the motor and the stator effectively prevent overheating of the components and are evaluated via the ACO MultiControl control.

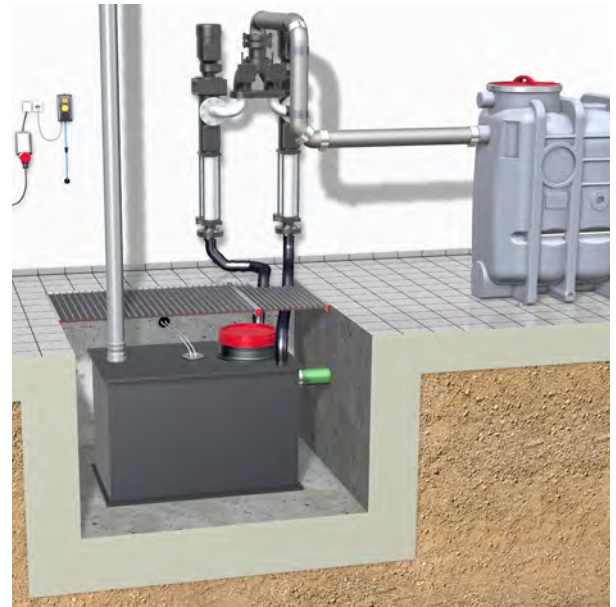

Installation examples for ACO upstream tank plants (special solutions on request)



Upstream tank plants: Special system solutions for grease separators



Product advantages

- Low-turbulence wastewater infeed to the grease separator due to displacement pumps
- Compact design
- Low energy consumption
- Reliable level control by use of air bubble injection

Suitable for:

- Greasy wastewater from commercial kitchens
- Light liquid separators (on request)

Product information

- Areas of use
 - Overcoming larger distance between where the wastewater is produced and the grease separator
 - Lower inlet connection upstream of the grease separator
- Tank made of polyethylene
 - 1x inspection opening for easy maintenance (350 mm clear width) with odourproof screw cover
 - Fixing set for buoyancy-proof anchorage
 - Screen insert positioned downstream of inlet
 - 1x horizontal inlet socket
 - DN 100, Ø 110 mm (Type 2 + 4)
 - DN 150, Ø 160 mm (Type 7 + 10)
 - 2x horizontal blank flanges usable as optional inlets
 - DN 100 (Type 2 + 4)
 - DN 150 (Type 7 + 10)
 - 1x vertical socket DN 100 (ventilation)
- 2 eccentric screw pumps
 - Geared motor 400 V, 50 Hz
 - Degree of protection IP 55
 - Integrated thermal monitoring
 - 10 m connection cable
- Formation of pressure line
 - Special backflow valve with ball in the housing, formed as a Y-branch pipe (integrated backwash and locking screw)
 - Special adapter for elastic connection of the pressure line DN 100 (pipe outside diameter: Ø 108 – 114.3 mm/ optional DN 80)
- Level switching
 - Pneumatic level switching with 10 m control cable
 - With air bubble injection via mini compressor
- Control
 - Degree of protection IP 54
 - Isolated group alarm and operation signal
 - Control box for type 10 with smooth start & stop

Order information

Type	Nominal diameter	Motor capacity	Current consumption	Inlet height	Usable volume	Total volume	Max. delivery performance	Total capacity	Weight		Article No.
									Empty	Filled	
		[kW]	[A]	[mm]	[l]	[l]	[l/s]	[l]	[kg]	[kg]	
2	DN 100	1.5	3.64	350	170	435	1.5	435	410	870	0175.30.25
4	DN 100	1.5	3.64	350	170	435	3.0	435	410	870	0175.27.84
7	DN 150	4.0	8.3	375	200	525	5.4	525	480	1020	0175.30.26
10	DN 150	4.0	8.3	450	340	645	7.7	645	680	1400	0175.30.32

Wastewater lifting plants

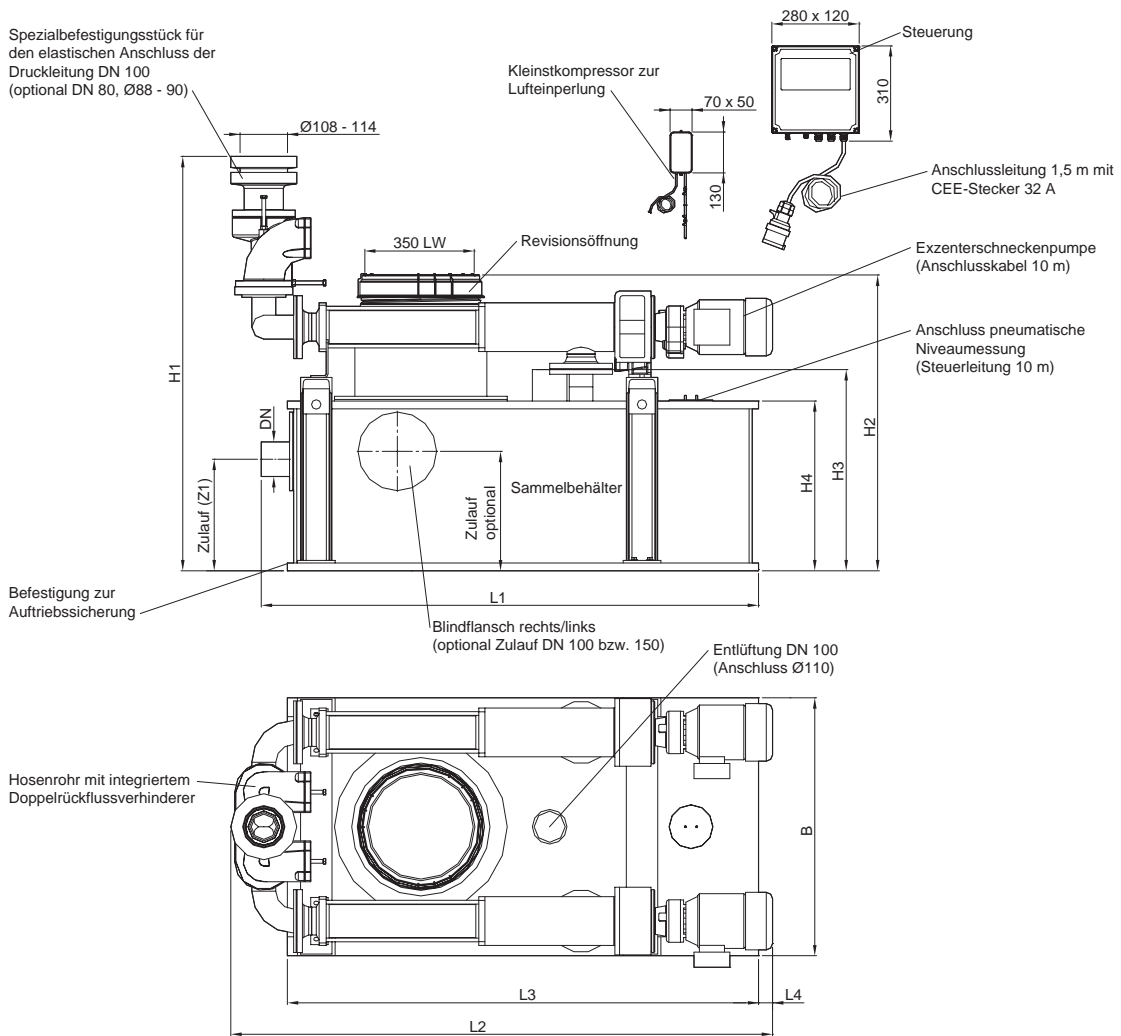

Dimensional drawing



Dimensions

Type	Nominal diameter	Dimensions									
		L1	L2	L3	L4	Inlet height	B	H1	H2	H3	H4
		[mm]	[mm]	[mm]	[mm]	[mm]	[mm]	[mm]	[mm]	[mm]	[mm]
2	DN 100	1580	1720	1500	45	350	820	1310	930	635	535
4	DN 100	1580	1720	1500	45	350	820	1310	930	635	535
7	DN 150	1880	1990	1800	0	375	820	1320	930	635	535
10	DN 150	1880	2250	1800	240	450	940	1450	1010	710	610

Accessories

Figure	Designation	Suitable for	Description	Article No.
	Signalling unit with GSM module	<ul style="list-style-type: none"> ■ Grease layer thickness measuring device ■ Odour neutralisation ■ Upstream tank plant <ul style="list-style-type: none"> <input type="checkbox"/> duo ■ Sinkamat-K (underfloor) <ul style="list-style-type: none"> <input type="checkbox"/> duo ■ All Muli lifting plants ■ Muli-Max-F 	<ul style="list-style-type: none"> ■ Mains-independent alarm ■ Visual and acoustic alarm signalling ■ Freely configurable inputs <ul style="list-style-type: none"> <input type="checkbox"/> 6 digital <input type="checkbox"/> 2 analog ■ 1 alarm output 12 V ■ Incl. GSM antenna (2.5 m cable) ■ Forwarding of the alarm to mobile phones by SMS text messaging ■ For installation outside the Ex zone ■ Housing: 178 x 125 x 102 mm (L x H x D) ■ Plug-in card for standard SIM card ■ Degree of protection: IP54 (with mounted antenna connector IP44) ■ Operating voltage: 230V/AC, 50/60 Hz 	0150.46.94
	Signalling unit	<ul style="list-style-type: none"> ■ All Muli wastewater lifting plants ■ duo upstream tank plant ■ Muli-Max-F ■ Sinkamat-S ■ Sinkamat-Z ■ Sinkamat-K (underfloor) <ul style="list-style-type: none"> <input type="checkbox"/> duo 	<ul style="list-style-type: none"> ■ Self-charging ■ With floating contact ■ Visual and acoustic ■ Without contactor ■ For installation outside the Ex zone ■ Housing: 175 x 125 x 75 mm (L x H x D) ■ Degree of protection: IP65 ■ Operating voltage: 230V/AC, 50/60 Hz ■ Ready to plug in, with cable: 2 m 	0150.26.73
	Connection and flood module set	<ul style="list-style-type: none"> ■ All wastewater lifting plants ■ Upstream tank plant <ul style="list-style-type: none"> <input type="checkbox"/> duo 	<ul style="list-style-type: none"> ■ For signalling a leakage triggered, e.g. by a pipe burst ■ For electrically conductive liquids ■ With floating contact ■ Visual and acoustic alarm signalling (approx. 80 dB) ■ Housing: 160 x 120 x 75 mm (L x H x D) ■ Degree of protection: IP 65 ■ Operating voltage: 230V/AC, 50/60 Hz ■ Ready to plug in ■ Cable length: 1.4 m ■ Flood detector with cable (10 m) 	0150.34.75

Wastewater lifting plants

Accessories

Figure	Designation	Suitable for	Description	Article No.
	Flashing light	<ul style="list-style-type: none"> ■ Multi-Max-F switching devices ■ Wastewater lifting plants with ACO Multi Control switching device 	<ul style="list-style-type: none"> ■ Description 230 V ■ Current consumption: 70 mA 	0178.62.08
	Signal horn	<ul style="list-style-type: none"> ■ Multi-Max-F switching devices ■ Wastewater lifting plants with ACO Multi Control switching device 	<ul style="list-style-type: none"> ■ Operating voltage: 230V AC ■ Current consumption: 15 mA ■ Dimensions: 172 x 70 x 78 mm (L x W x D) ■ Degree of protection: IP33 ■ 92 dB(A) 	0178.61.94
	Signal horn	<ul style="list-style-type: none"> ■ Signalling unit ■ Signalling unit with GSM module 	<ul style="list-style-type: none"> ■ Operating voltage: 12V AC ■ Current consumption: 15 mA ■ Dimensions: 172 x 70 x 78 mm (L x W x D) ■ Degree of protection: IP33 ■ 92 dB(A) 	0150.58.14
	Air bubble injection	<ul style="list-style-type: none"> ■ Multi-Star DDP 1/2 ■ Multi-Mini 	<ul style="list-style-type: none"> ■ For retrofitting in Multi-Mini and Multi-Star DDP wastewater lifting plants ■ With mini compressor and connection materials ■ To increase operating reliability ■ In case of formation of floating surface cover (greasy wastewater) 	0154.81.27
	Air bubble injection	<ul style="list-style-type: none"> ■ Multi-PE S duo 	<ul style="list-style-type: none"> ■ For increasing the operating reliability where floating surface cover forms (e.g. grease separator) ■ Pneumatic pipe with mini compressor: 230V 	0159.00.48
	Ball valve 2"	<ul style="list-style-type: none"> ■ Multi-Mini 	<ul style="list-style-type: none"> ■ As supplementary component for pressure line 	0159.31.79
	Hex double nipple 2" x 2"	<ul style="list-style-type: none"> ■ Multi-Mini 	<ul style="list-style-type: none"> ■ Made of stainless steel, Material grade 304 ■ For changeover from IG 2" to AG 2" of the pressure line 	0155.00.44
	Special adapter DN 50	<ul style="list-style-type: none"> ■ Multi-Mini 	<ul style="list-style-type: none"> ■ As supplementary component for pressure line DN 50 (OD: 57 – 61 mm) 	0175.16.84



Figure	Designation	Suitable for	Description	Article No.
	Special adapter DN 50	■ Multi-Mini	■ As supplementary component for pressure line DN 50 (OD: 48 – 52 mm)	0175.32.32
	Inlet socket DN 50	■ Multi-Mini	■ Made of plastic ■ For lateral inlet option ■ For on-site installation ■ Weight: 0.1 kg	2410.00.04
	Inlet stop valve DN 50	■ Multi-Mini	■ Made of PVC ■ DN 50 ■ With sealing ring to DIN 19538	0175.18.33
	Stop valve DN 80	■ Multi-Star DDP 1/2	■ Made of cast iron ■ 8 bolts and nuts ■ 1 seal DN 80 ■ Overall length: 180 mm ■ Weight: 21 kg	0154.51.93
	Stop valve DN 80	■ Wastewater lifting plants	■ Made of cast iron ■ For pressure line ■ Overall length: 180 mm ■ Weight: 21 kg	0159.09.89
	Stop valve DN 100	■ Wastewater lifting plants	■ Made of cast iron ■ For pressure line ■ Overall length: 190 mm ■ Weight: 32 kg	0159.09.90
	Fixing kit	■ Stop valve □ 0159.09.89	■ 8 bolts and nuts ■ 1 seal	0159.00.19
	Fixing kit	■ Stop valve □ 0159.09.90	■ 8 bolts and nuts ■ 1 seal	0159.00.20

Wastewater lifting plants

Accessories

Figure	Designation	Suitable for	Description	Article No.
	Inlet stop valve DN 100	<ul style="list-style-type: none"> ■ Wastewater lifting plants ■ Upstream tank plants □ duo 	<ul style="list-style-type: none"> ■ Made of PVC ■ Push-socket 110 mm with lip sealing ring on both sides ■ Overall dimensions: 176 x 330 mm (L x H) ■ Weight: 2.75 kg 	0175.13.84
	Inlet stop valve DN 100	<ul style="list-style-type: none"> ■ Upstream tank plants □ mono/duo 	<ul style="list-style-type: none"> ■ Made of PVC ■ Spigot on both sides 110 mm for socketless pipe systems made of cast iron or plastic ■ Overall dimensions: 176 x 360 mm (L x H) ■ Weight: 4.0 kg 	0175.31.87
	Stop valve DN 150	<ul style="list-style-type: none"> ■ Wastewater lifting plants ■ Upstream tank plant □ duo 	<ul style="list-style-type: none"> ■ Made of PVC ■ Spigot on both sides 160 mm for socketless pipe systems made of cast iron or plastic ■ Overall dimensions: 226 x 420 mm (L x H) ■ Weight: 8.0 kg 	0175.31.88
	Stop valve DN 150	<ul style="list-style-type: none"> ■ Wastewater lifting plants ■ Upstream tank plants □ duo 	<ul style="list-style-type: none"> ■ Made of PVC ■ Push-socket 160 mm with lip sealing ring on both sides ■ Overall dimensions: 226 x 510 mm (L x H) ■ Weight: 6.5 kg 	0175.13.85
	Manual diaphragm pump R 1 1/2"	<ul style="list-style-type: none"> ■ Wastewater lifting plants 	<ul style="list-style-type: none"> ■ For wall mounting ■ Incl. hose □ Clear width: 48 mm ■ Incl. hose clamps 	0175.23.73

Accessories

Figure	Designation	Suitable for	Description	Article No.
	Three-way valve R 1½"	<ul style="list-style-type: none"> ■ Wastewater lifting plants 	<ul style="list-style-type: none"> ■ For manual diaphragm pump 	0159.10.14
	Stop valve R 1½"	<ul style="list-style-type: none"> ■ Wastewater lifting plants 	<ul style="list-style-type: none"> ■ For manual diaphragm pump 	0159.10.12
	Switchbox cover with main switch	<ul style="list-style-type: none"> ■ Wastewater lifting plants □ duo 	<ul style="list-style-type: none"> ■ Switchbox cover with main switch, replaces the existing switchbox cover without main switch ■ By actuating the main switch the entire plant is disconnected from the mains 	0150.33.86
	Toroidal sealing ring	<ul style="list-style-type: none"> ■ Upstream tank plant □ duo ■ All Muli wastewater lifting plants 	<ul style="list-style-type: none"> ■ As supplementary component for pressure line DN 80 	0159.37.97

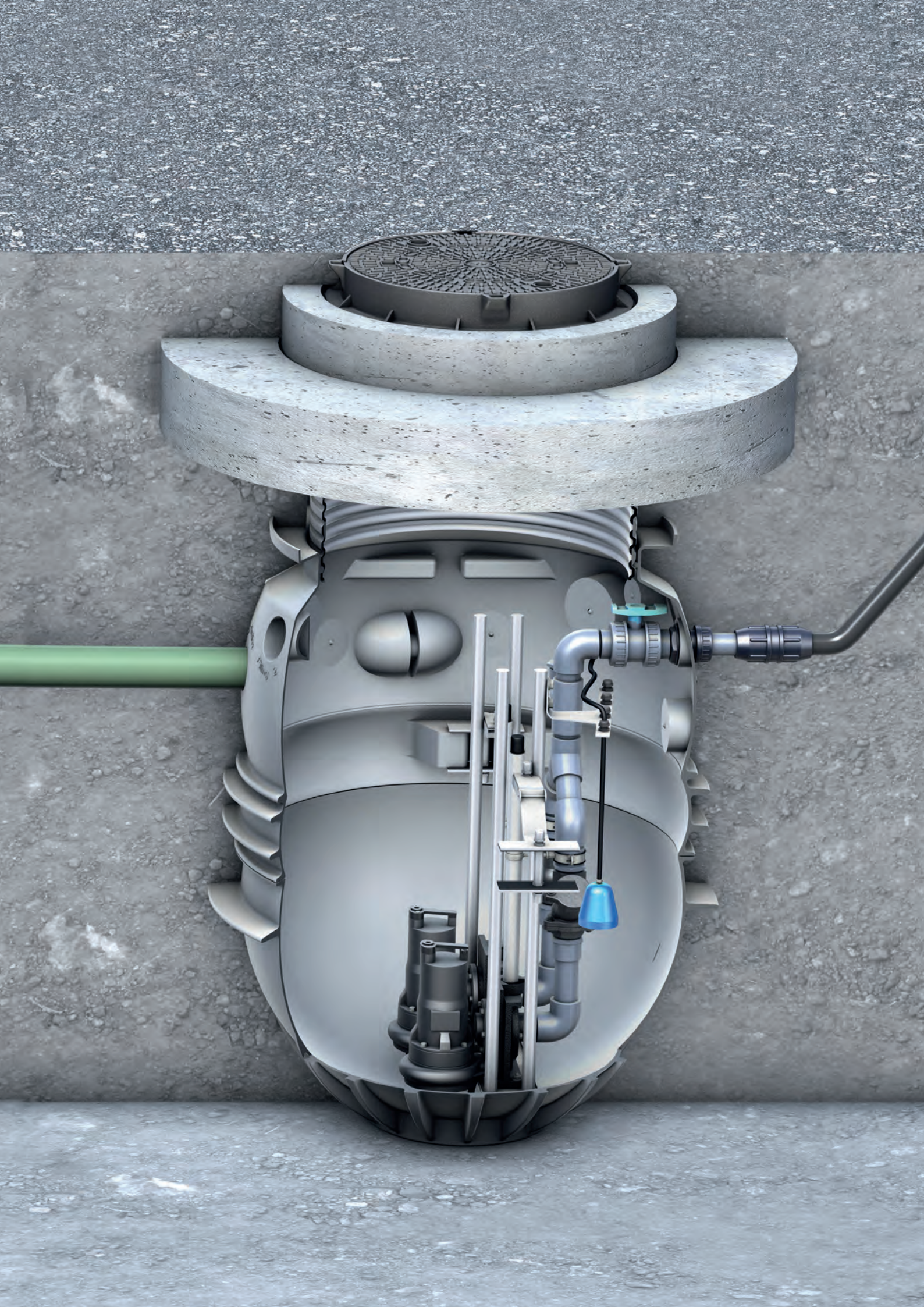

Pumping stations – Product Overview

In several construction projects a pumping station is installed in the ground outside the building instead of a freestanding wastewater lifting plant installation in the building.

The advantages are not only the space savings but also the ability to also safely drain away rainwater falling outside the building.

The size of the pumping station to be installed depends on the flow rate discharged or the nominal size of the upstream separator. The tanks of the ACO pumping stations are made of polyethylene and are characterised, among other things, by their high stability, good resistance and maximum protection against buoyancy. ACO pumping stations are built according to a modular principle: the customer can choose the load class, the control, the type of level measurement, the pump and diverse accessories.

If a shaft is already available on site or if it is to be renovated, the ACO Powerlift installation kit in dimensions DN 50 or DN 100 offers the solution. This preassembled installation can be placed in the shaft easily and adapted to the given conditions on site. Here too it is possible to choose between a large number of pumps for black or grey water and diverse accessories.

Basic principles

Protection against backflow

In DIN 1986-100 "Drainage systems on private ground" and EN 12056 "gravity drainage systems inside buildings" it is specified that wastewater produced below the backflow level and rainwater from surfaces below the backflow level must be fed, backflow free, into the public sewers via an automatically operating lifting plant/pumping station. The basic principle when designing a drainage system is "to guide surface water away from the building and not to draw it into the building". Accordingly, rainfall runoff areas must be drained via separate pumping stations outside the building.

All sanitary appliances located above the backflow level are to be drained with natural slope (gravity principle); the wastewater from these sanitary appliances must not be drained via backflow stops and only in absolutely necessary exceptional cases (e.g. renovation of old buildings) may it be drained via lifting plants/pumping stations. If the competent authority has not defined the backwater level, the road level at the connection point is deemed to be the backflow level.

Pressure line

a) Backflow level

The backflow level is the highest point in an installation up to which the contaminated water can rise. The backflow level is located in the area of the largest cross-section widening. Installations should be designed so that the water in the sewer cannot flow back into the pumping station. This could happen in the event of storms, floods and heavy rainfall events, if the municipal sewers are not designed for such quantities. Damage caused by this is not covered by insurance companies and only in rare cases are claims legally enforceable. The operator/owner is responsible for protecting the building. Information about the height of the backflow level is given in the local byelaws.

b) Backflow loop A backflow loop constitutes artificially raised pipe routing above the backflow level, so that backflowing water can be distributed in all lower lying free spaces first. As it can be assumed that an adequate volume is available in the overall pipe system, the backflow loop constitutes the most reliable alternative against backflow. In case of poor/lack of backflow protection the installer or design engineer is liable.

Electrical installation

The electrical installation must be carried out by a qualified electrician. Switching devices and signalling units must be installed in a dry, easily accessible place. The signalling unit must also be installed in a place where it can be easily seen and heard.

Installation

Buoyancy protection

Buoyancy protection is the fixing of a plant/pump onto the floor (or onto the pump shaft in the ground), to prevent it from floating up in case of flooding (or raised groundwater level) of the area, as damage to connections/pipes could occur, which could cause the medium to leak. The buoyancy protection is located directly on tanks or is installed subsequently or is already cast on. It should be ensured that the plant/pump is securely stood on the ground, protected against twisting, and therefore cannot start to move or turn.

Usable volume

The usable volume – also called required impoundment volume – is generally the term used to describe the volume between the pump switching on and switching off point. The usable volume must always be taken into account in the design of the pumping station.

For substances and liquids which spread harmful or unpleasant vapours or odours, which attack the materials of the drainage installations or disrupt operations, plants must be installed upstream of them, which prevent these substances and liquids from penetrating the wastewater lifting plant. Such plants are, in particular:

Oil or petrol interceptors to EN 858/
DIN 1999-100, fuel oil valves to
DIN 4043, demulsifiers, grease separators
to EN 1825/DIN 4040-100, starch separa-
tors to factory standards, grit and sludge
traps and neutralisation plants.

Shaft / manhole covers

Load classes		Tonnes
A 15	Walk-on-able	1.5
B 125	car-trafficable	12.5
D 400	truck-trafficable	40.0

Layout and design

- All relevant byelaws, regulations and standards must be taken into account in the layout and design.
- Suitable pumps, level controls and switching devices must be selected depending on the pumped medium, grey water (non-faecal) or black water (faecal).
- The dimensions of the collection shaft must be designed to satisfy all contradictory requirements. Here the best possible compromise must be found.
- For example, the usable volume of the shaft must be as large as possible (to keep the number of pump starts per hour low). Furthermore, the usable volume of the shaft must be greater than the capacity of the pressure pipe, in order to prevent continuous switching on of the pump in case of a defective non-return flap. On the other hand, the usable volume of the shaft should be small, to prevent deposits and fouling of the wastewater, including in the pressure pipe.
- If lengthy standstill periods are to be expected in plants (e.g. stormwater pumping stations), suitable measures are to be taken to ensure their operational reliability. Here, for example, use of vortex impeller pumps can prevent the running part of the pump from rusting and sticking. Equally, regular forced switching on of a channel impeller pump can prevent rusting of the running part.
- When choosing the location of the pumping station, it must be checked for traffic load incidence and structurally adequate collection shafts must be selected. Here the relevant load classes are A 15 (walk-on-able), B 125 (trafficable up to 12.5 t) and D 400 (trafficable up to 40 t) loosely positioned and bolted.
- The pumping station installation must be buoyancy and frost resistant. Furthermore, good ventilation of the collection chamber must be ensured.
- Switching devices must be installed in dry rooms or in suitable outdoor pillars.
- The pumped medium and distance to the switchbox must be taken into account when selecting the level switching
- The delivery performance (quantity and head) and the quality of the wastewater are very important when selecting the pump. Operation of the pump outside of the characteristic range must be avoided (risk of cavitation and vibration). Ensure compliance with the allowable flow velocities.
- When choosing the pressure line materials as few base and precious metals/base and refined materials as possible must be mixed to avoid stress corrosion.
- To ensure the greatest possible protection against backflow from public sewers, the invert of the pressure pipe must be laid above the backflow level (highest point up to which the water can rise, in most cases the road level). Attention must be paid to protection against frost (e.g. installation in heated outdoor cabinet with frost monitor).

Municipal law, wastewater byelaws/local byelaws

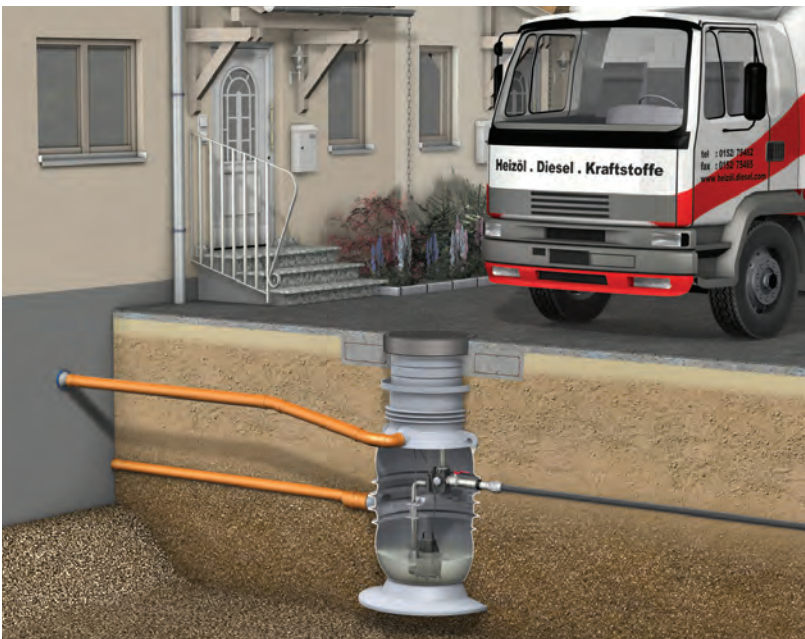

- Property or site drainage systems are to be connected to the public sewers to state of the art standards.
- If the wastewater contains hazardous substances, pretreatment plants (separators) must be installed upstream of the discharge point.
- Wastewater or rainwater, which is produced below the backflow level (mostly the road level), must be drained without backflow.
- Drainage systems whose static water level is below the backflow level must be protected against backflow.
- Drainage systems must be installed in a frost free location/depth.

When designing permanently functioning drainage, all sanitary appliances along the drainage run must be considered together. All regulations and standards must be followed. Standards often list cross-references which must also be taken into account.

State-of-the-art

EN 12056-1 Gravity drainage systems inside buildings	Backflow protection Wastewater produced below the backflow level must be fed into the drainage system via an automatic wastewater lifting plant. Backflow stops are allowed in exceptional cases.
EN 752-4 Drain and sewer systems outside buildings	The drainage system must be designed for protection against flooding and overload in case of rainfall events with defined intensities and frequencies, taking into account the backflow lines.
EN 858-2 Separator systems for light liquids	The light liquid must not escape from the separator plant or from the top sections. The separator plant must be connected to the drainage system according to the local regulations.
EN 1825-2 Grease separators	Connections to the drainage system Where there are no official requirements, separator plants for greases must be connected to the sewers as follows. The wastewater must be fed to the separator plant with a free gradient. Separators for greases, whose static water level is below the backflow level (see EN 752-1), must be drained via a downstream lifting plant.

Backflow protection for grease separators installed in the ground

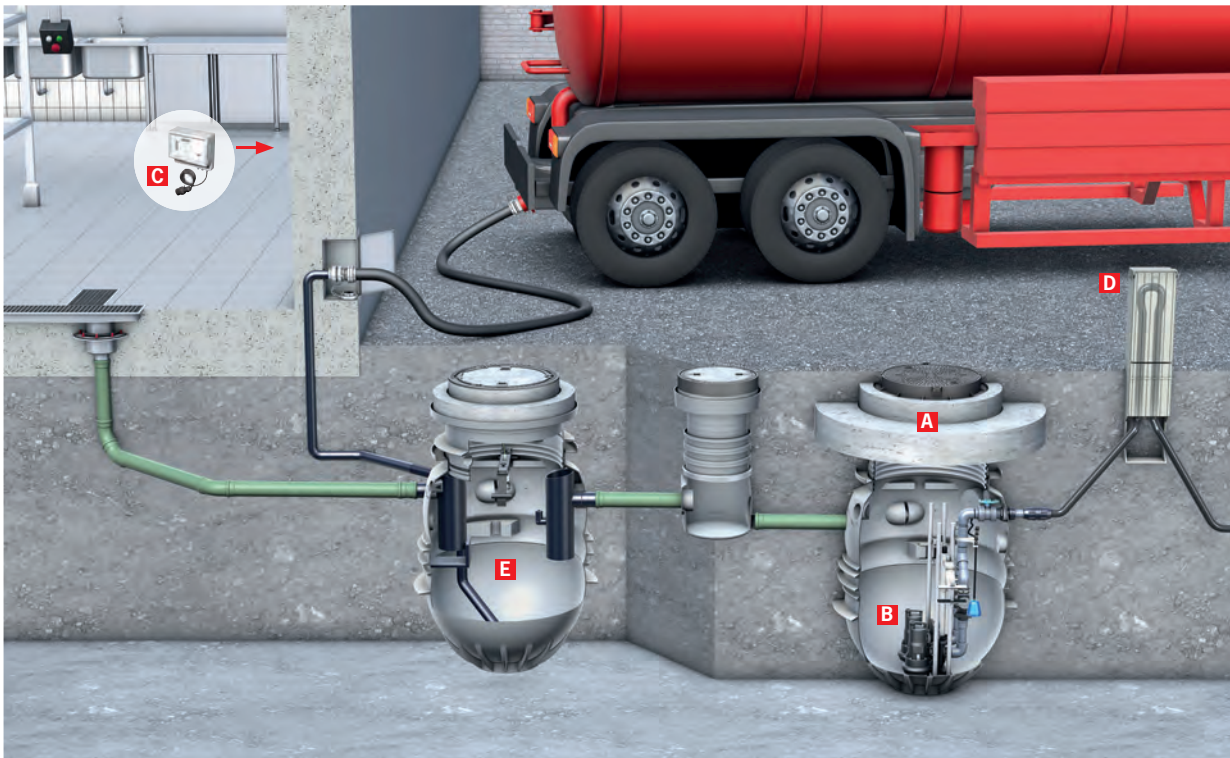

- A**
 - Note load class of pumping station top section: A (walk-on-able), B (car trafficable), D (truck trafficable) depending on installation site
 - Calculate usable volume of the collection shaft, depending on the inlet quantity and the maximum switching frequency of the pump
 - Note the groundwater level and calculate the buoyancy behaviour
 - Define the installation depth according to the inlet depth and local frost limit
- B**
 - Calculate pump performance required to EN 12056-4
 - Select pump type (channel impeller, vortex impeller, cutting impeller) based on the delivery head, delivery rate and pumped medium
- C**
 - Install switchbox in a dry place in the building or on the site in a weather-proof heated outdoor cabinet
- D**
 - Install pressure pipe in frostproof place above the backflow level (normally street level) or on the site in a weatherproof heated outdoor cabinet
- E**
 - ACO Lipumax grease separator for installation in the ground

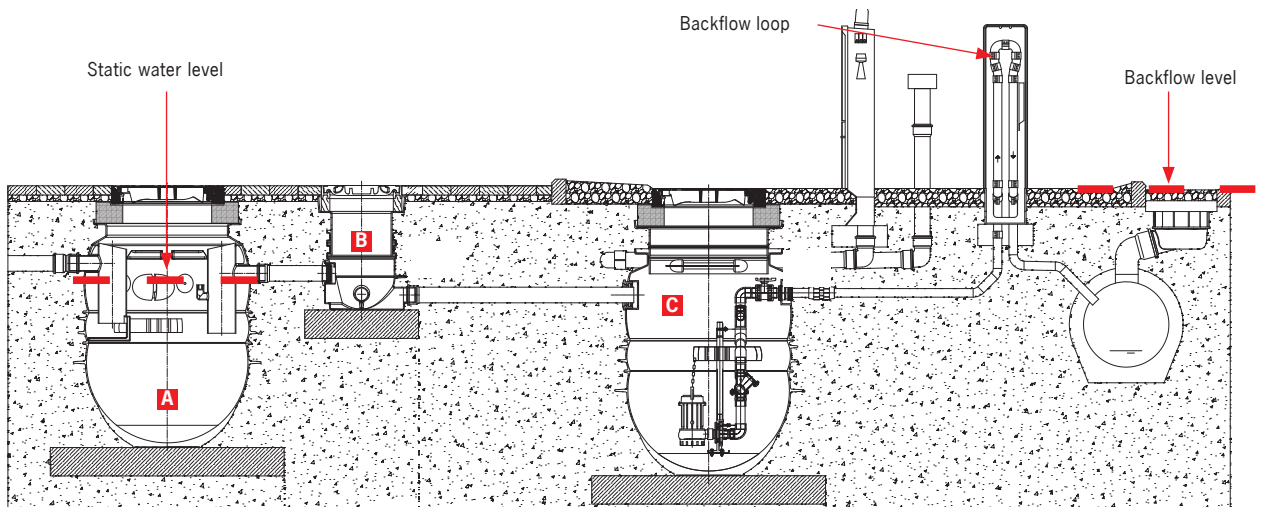

A Grease separator

If the wastewater contains hazardous substances, pretreatment plants (separators) must be installed upstream of the discharge point. Drainage systems must be installed in a frost free location/depth. Municipal law applies.

- The static water level of a separator installed in the ground is almost always below the backflow level and must be protected against backflow accordingly.
- Where a raised installed separator is possible, the backflow level must be used as the reference level and not the lowest inlet point. In case of backflow drainage is then no longer ensured and a possible escape of harmful liquids cannot be prevented.

B Sampling shaft

Connection of the drainage system to the public sewer network to state-of-the-art standards. Municipal law applies.

C Pumping station (Powerlift - P)

The separator is connected to the public sewers taking into account the following standards:

EN 12056, EN 752 and is to state-of-the-art standards

- According to the relevant standards, installation of a passive backflow stop is not allowed.
- 100% backflow protection is only possible by drainage via a pumping station with pressure line routing above the backflow level.
- A separator installed downstream of the pumping station is designed in accordance with EN 12056 and EN 752.



Product version

Muli-Max-F prefabricated pumping station (installed in the ground)

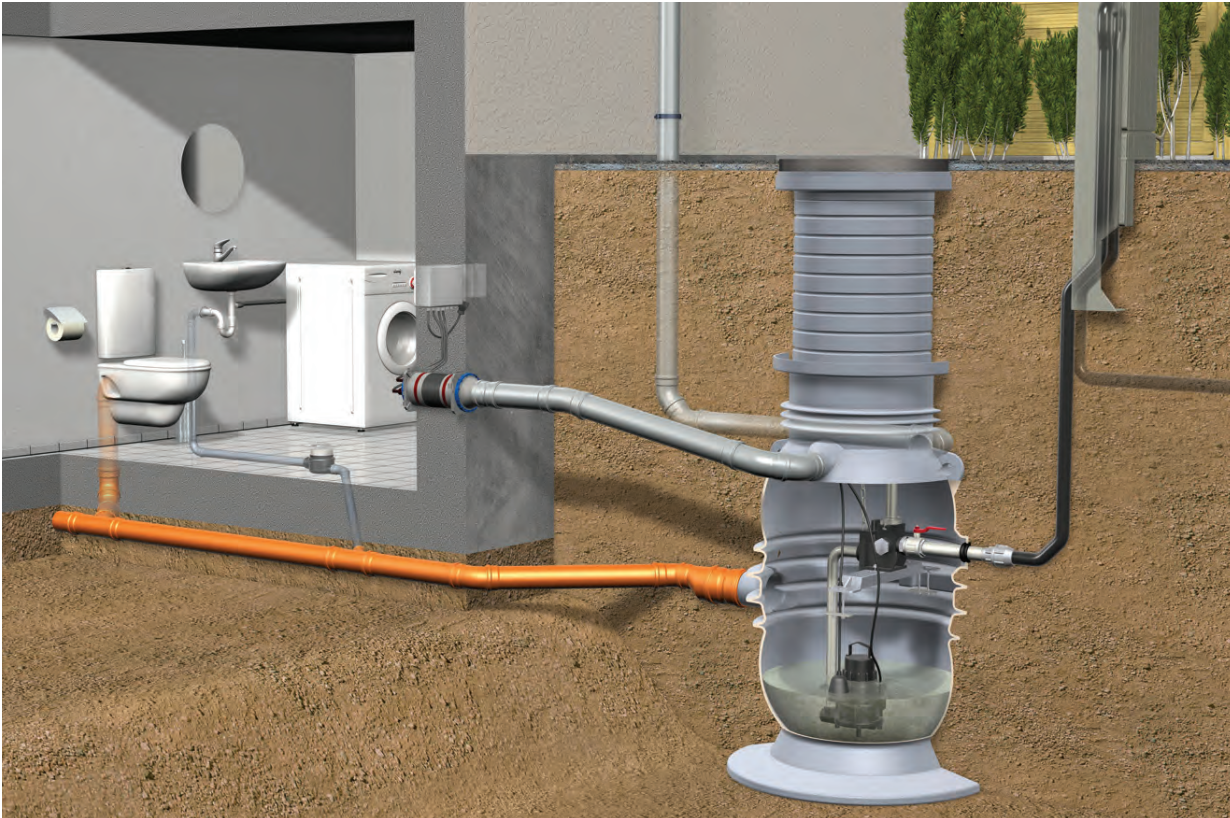

Area of use

The Muli-Max-F pump shaft is especially suitable for the drainage of detached and multi-dwelling houses, office buildings and industrial buildings and for siphonic drainage. Furthermore, grease separators up to nominal size 4 can be drained. The pumping stations are designed for non-faecal and faecal wastewater and are available as single or twin pumping stations

Special features

The shafts are made of polyethylene and have a very compact design. The piping is made of stainless steel. The retaining valve, the traverse and the automatic coupling are made of cast iron. The level is measured via a backpressure bell as a standard feature, but on request a 4–20 mA pressure pick-up can be used. If the plant is installed downstream of a grease separator, use of the backpressure bell in conjunction with the optional air bubble injection kit is recommended.

Pump types:

- Five vortex impeller pumps (non-faecal)
- Three cutter impeller pumps (ATEX conformant: faecal & non-faecal)

Covers:

- Class A15 (walk-on-able)
- Class B125 (trafficable by cars)
- Class D400 (trafficable by trucks)

The covers are designed so that they can be installed on site without complicated concreting work, e.g. additional reinforcement in the area of the cover. The pumps are lowered to the automatic above water coupling using the guide belts supplied and are fixed using these belts. This installation or dismantling is carried out without tools.

Product version

Powerlift - P prefabricated pumping stations (for installation in the ground)

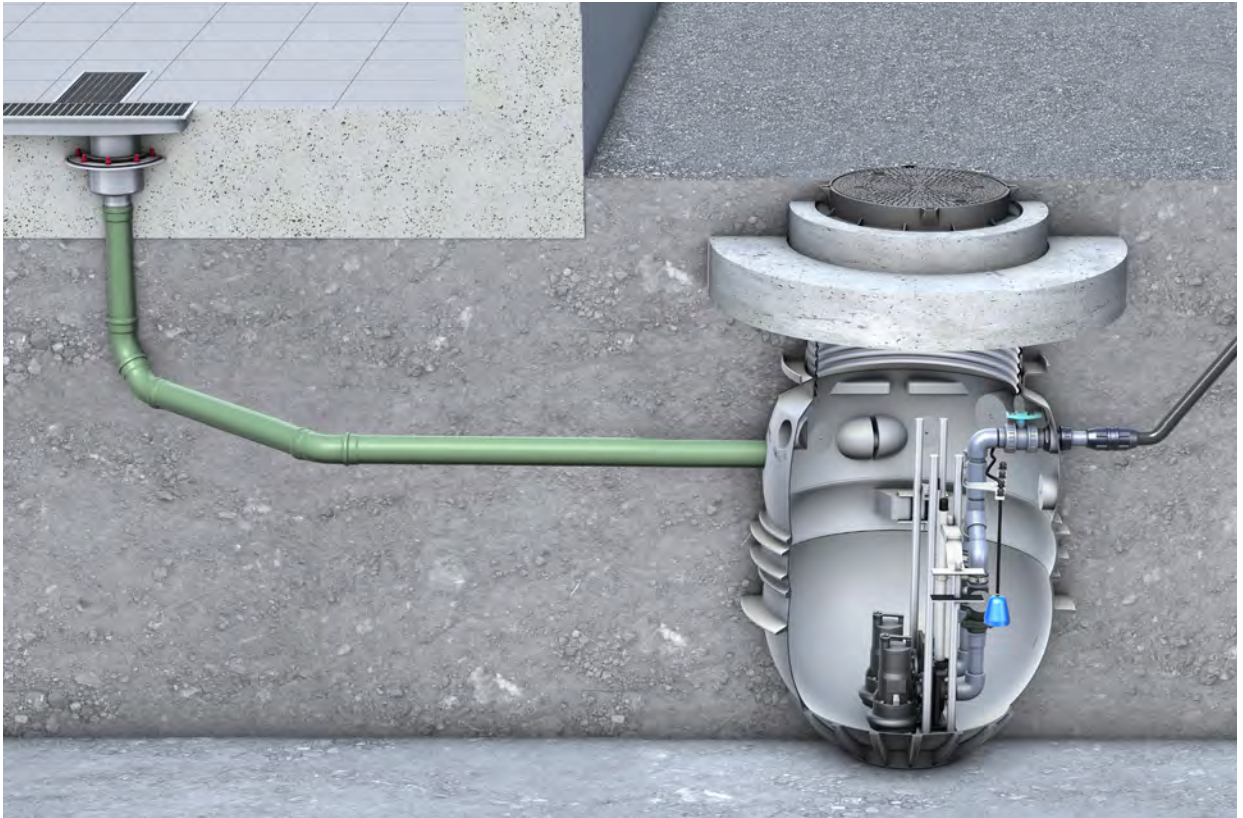

Area of use

The Powerlift-P duo is the first choice when it comes to large usable volumes. The usable volume here is up to 550 litres, which means that this pumping station is also suitable for draining a separator up to nominal size 10 and for draining medium to large outdoor areas (e.g. ramps and inner courtyards). The pumping stations are designed for non-faecal and faecal wastewater and are available as single or twin pumping stations.

Special features

The tanks are made of polyethylene material. The pressure line is made of very lightweight PVC-U material. This material is primarily characterised by its outstanding chemical resistance and absolute corrosion resistance. The level is measured via a backpressure bell as a standard feature, but on request a 4–20 mA pressure pick-up or a flow switch can also be used.

Pump types:

- Three vortex impeller pumps (non-faecal)
- Three **cutter** impeller pumps (ATEX conformant: faecal & non-faecal)

Covers:

- Class B125 (trafficable by cars)
- Class D400 (trafficable by trucks)

The covers are designed so that they can be installed on site without complicated concreting work, e.g. additional reinforcement in the area of the cover. The integrated guide pipes make installing and dismantling the pumps easier, whereby the pumps are sealed in the automatic underwater coupling without tools.

Product version

Powerlift installation kit for on-site shafts

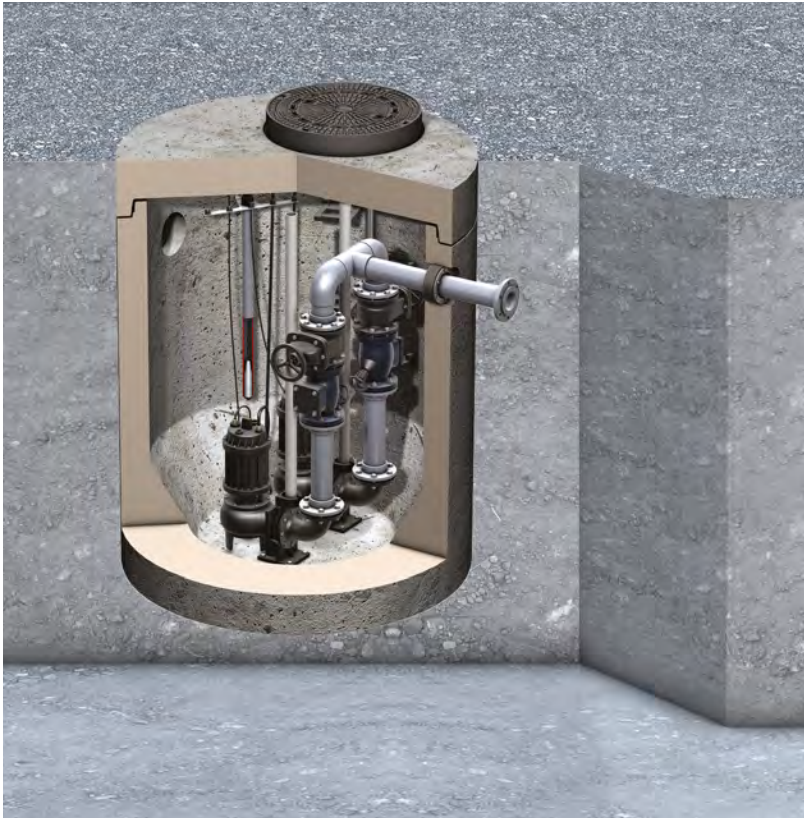

Area of use

The Powerlift installation kit has been designed for on-site shafts, whereby the shaft shape (round or square) is irrelevant. The overall height and equipment of the plant can be adapted using the modular principle and thus offer maximum flexibility. The installation kit is suitable for the drainage of detached and multi-dwelling houses, for surface drainage (e.g. ramps, inner courtyards), for business and industrial parks and downstream of diverse separator plants.

Special features

The piping is delivered preassembled and is available in DN 50 or DN 100. The pump kit is designed for both non-faecal and faecal wastewater and is available as a mono and a duo version. The kit can be quickly adapted to the respective circumstances on site. The pump kit DN 50, which is mainly made of PVC-U, provides all the necessary materials. The level measurement by means of float switch, pressure pick-up or open backpressure bell can be attached and securely fastened in an optional holder.

Pump types:

- Three vortex impeller pumps (non-faecal)
- Three **cutter** impeller pumps (ATEX conformant: faecal & non-faecal)
- Eight channel impeller pumps

Product selection matrix

Product features	Muli-Max-F	Powerlift - P	Powerlift installation kit
Non-faecal and faecal wastewater	yes	yes	yes
Covers	A15, B125, D400	B125, D400	Depending on the situation on site
Choice of vortex impeller pumps	5	3	3
Choice of cutter impeller pumps	3	3	3
Choice of channel impeller pumps	-	-	8
Ready to install	yes	yes	Use of an existing shaft
Usable volume	up to 150 litres	up to 550 litres	Depending on the situation on site
Drainage of grease separators	up to nominal size 4	up to nominal size 10	Depending on shaft size
Typical areas of use	<ul style="list-style-type: none"> ■ Private households ■ Office buildings ■ Small industry 	<ul style="list-style-type: none"> ■ Industrial buildings ■ Ramps ■ Large roof areas ■ Outdoor areas and courtyards 	<ul style="list-style-type: none"> ■ Industrial buildings ■ Ramps ■ Large roof areas ■ Outdoor areas and courtyards

Pumping stations

ACO Multi-Max-F mono/duo prefabricated pumping station Load class A 15



Product advantages

- Overall installation depth up to 3000 mm
- Pneumatic level switching for high operational safety
- Buoyancy proof and groundwater tight up to ground level
- Can be installed without on-site concreting works

Suitable for:

- Grey and black water
- Use downstream of grease separators up to NS 4

Product information

- Areas of use
 - Detached and multi-dwelling houses
 - Office buildings
 - Industrial buildings
 - Siphonic drainage
- Individual pump station (duo pump station) for installation in the ground made of polyethylene
- Shaft section made of polyethylene, clear width: 900 mm
- With automatic above-water coupling
 - For holding ACO Passavant submersible motor pumps
- With pressure line outlet made of stainless steel and 1 (2) ball valve R ½", pressure line connection DN 40 or R 2", pressure line changeover outside to DN 50
- Dimensions from top of shaft to middle of pressure line: 1050 mm, positioned at 9 o'clock
- 1 inlet DN 150, dimension from bottom of shaft to middle of inlet: 775 mm, positioned at 3 o'clock (seal enclosed in separate pack)
- 1 connection port DN 100 for cable conduit/ventilation, positioned at 6 o'clock and 12 o'clock, connection height: 1439 mm from bottom of shaft to middle
- Connection port with socket R ½" for flushing connection (accessory)
- 1 shaft cover (loosely positioned)
 - Load class: A 15 (to EN 124)
 - Clear width: 600 mm
 - Without ventilation
- Pressure line connection R 2" or 1½"
 - Ball-type retaining valve
 - Stainless steel piping and guide element to the above-water coupling
 - Stainless steel chain, length: 1.5 m
- ACO Passavant system
 - Official approval Z-42.1-418

Order information

Type	Description	Height [mm]	Usable volume up to [l]	Weight [kg]	Article No.
mono	Cover: placed loosley	1900	150	175	0178.08.70
duo	Cover: placed loosley	1900	150	200	0178.08.71

Dimensional drawing

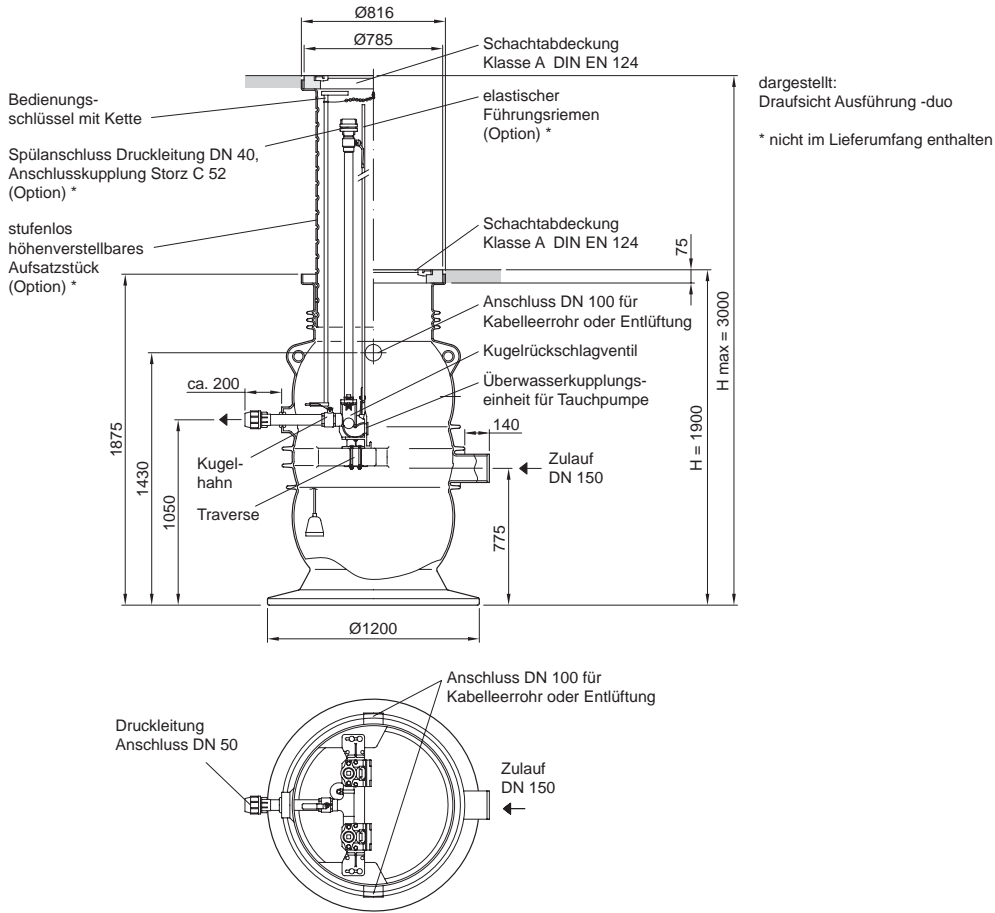

Order information (pumps)

Pump	Impeller	Type of wastewater/ Operating mode	Weight [kg]	Article No.	
				mono	duo
Sita 200 N-ex	Grinder	Faecal/S1	38	0178.09.08	2 x 0178.09.08
Sita 260 N-ex	Grinder	Faecal/S1	45	0178.08.53	2 x 0178.08.53
Sita 300 N-ex	Grinder	Faecal/S1	60	0178.08.59	2 x 0178.08.59
Sat-V 75/2/50/D	Vortex impeller	Non-faecal/S3	22	0178.08.54	2 x 0178.08.54
Sat-V 150/2/50/D	Vortex impeller	Non-faecal/S3	30	0178.08.55	2 x 0178.08.55
Sat-100/D	Open impeller	Non-faecal/S1	30	0178.08.56	2 x 0178.08.56
Sat-150/D	Open impeller	Non-faecal/S1	32	0178.08.57	2 x 0178.08.57
Sat-200/D	Open impeller	Non-faecal/S1	32	0178.08.58	2 x 0178.08.58

Details of submersible pumps from page 64

Pumping stations

ACO Multi-Max-F mono/duo prefabricated pumping station Load class B 125



Product advantages

- Overall installation depth up to 3000 mm
- Pneumatic level switching for high operational safety
- Buoyancy proof and groundwater tight up to ground level
- Can be installed without on-site concreting works
- Car trafficable

Suitable for:

- Grey and black water
- Use downstream of grease separators up to NS 4

Product information

- Areas of use
 - Detached and multi-dwelling houses
 - Office buildings
 - Industrial buildings
 - Siphonic drainage
- Individual pump station (duo pump station) for installation in the ground made of polyethylene
- Shaft section made of polyethylene, clear width: 900 mm
- With automatic above-water coupling
 - For holding ACO Passavant submersible motor pumps
- With pressure line outlet made of stainless steel and 1 (2) ball valve R ½", pressure line connection DN 40 or R 2", pressure line changeover outside to DN 50
- Dimensions from top of shaft to middle of pressure line: 1050 mm, positioned at 9 o'clock
- 1 inlet DN 150, dimension from bottom of shaft to middle of inlet: 775 mm, positioned at 3 o'clock (seal enclosed in separate pack)
- 1 connection port DN 100 for cable conduit/ventilation positioned at 6 o'clock and 12 o'clock connection height: 1439 mm from bottom of shaft to middle
- Connection port with socket R ½" for flushing connection (accessory)
- 1 manhole cover
 - Load class: B 125 (to EN 124)
 - Clear width: 600 mm
 - Without ventilation, incl. 2 operating keys
- Pressure line connection R 2" or 1½"
 - Ball-type retaining valve
 - Stainless steel piping and guide element to the above-water coupling
 - Stainless steel chain, length: 1.5 m
- ACO Passavant system
 - Official approval Z-42.1-418

Order information

Type	Description	Height [mm]	Usable volume up to [l]	Weight [kg]	Article No.
mono	Cover: placed loosley	1950	150	160	0178.08.72
duo	Cover: screwed shut odour-proof	1950	150	160	0178.08.73
mono	Cover: placed loosley	1950	150	180	0178.09.04
duo	Cover: screwed shut odour-proof	1950	150	180	0178.09.06

Dimensional drawing

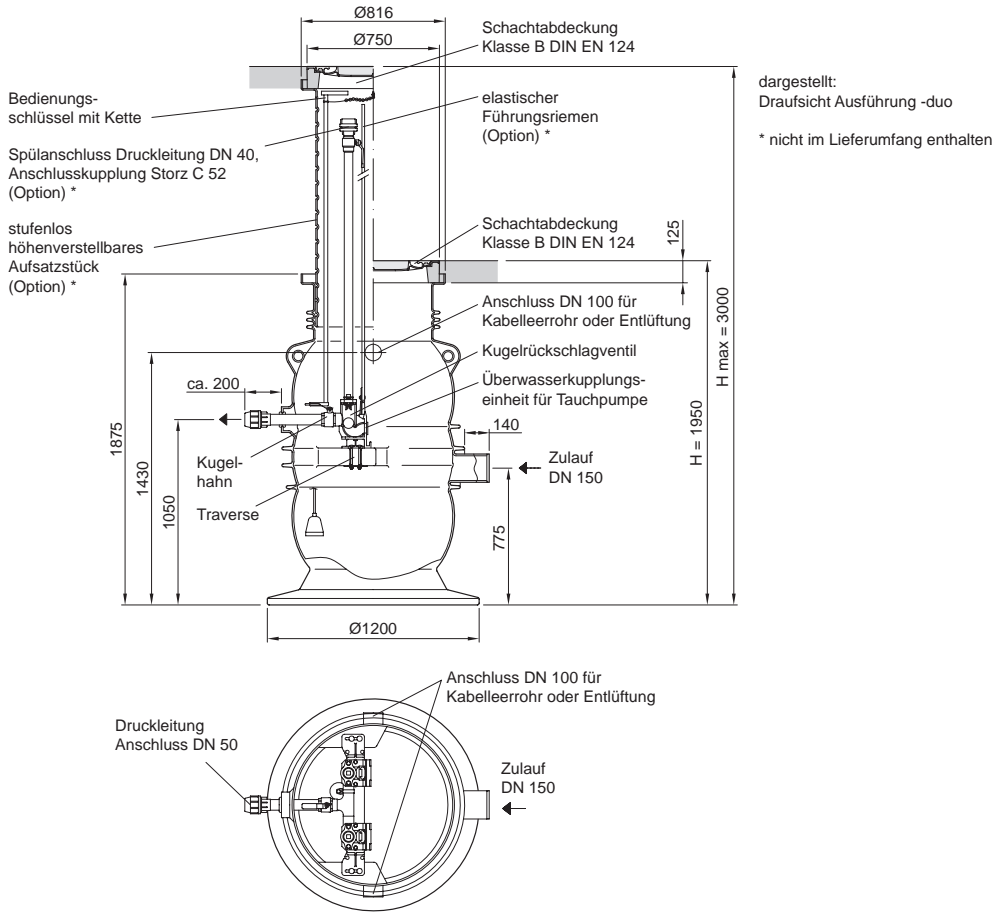

Order information (pumps)

Pump	Impeller	Type of wastewater/ Operating mode	Weight [kg]	Article No.	
				mono	duo
Sita 200 N-ex	Grinder	Faecal/S1	38	0178.09.08	2 x 0178.09.08
Sita 260 N-ex	Grinder	Faecal/S1	45	0178.08.53	2 x 0178.08.53
Sita 300 N-ex	Grinder	Faecal/S1	60	0178.08.59	2 x 0178.08.59
Sat-V 75/2/50/D	Vortex impeller	Non-faecal/S3	22	0178.08.54	2 x 0178.08.54
Sat-V 150/2/50/D	Vortex impeller	Non-faecal/S3	30	0178.08.55	2 x 0178.08.55
Sat-100/D	Open impeller	Non-faecal/S1	30	0178.08.56	2 x 0178.08.56
Sat-150/D	Open impeller	Non-faecal/S1	32	0178.08.57	2 x 0178.08.57
Sat-200/D	Open impeller	Non-faecal/S1	32	0178.08.58	2 x 0178.08.58

Details of submersible pumps from page 64

Pumping stations

ACO Multi-Max-F mono/duo prefabricated pumping station Load class D 400



Product advantages

- Overall installation depth up to 3000 mm
- Pneumatic level switching for high operational safety
- Buoyancy proof and groundwater tight up to ground level
- Can be installed without on-site concreting works
- Truck trafficable

Suitable for:

- Grey and black water
- Use downstream of grease separators up to NS 4

Product information

- Areas of use
 - Detached and multi-dwelling houses
 - Office buildings
 - Industrial buildings
 - Siphonic drainage
- Individual pump station (duo pump station) for installation in the ground made of polyethylene
- Shaft section made of polyethylene, clear width: 900 mm
- With automatic above-water coupling
 - For holding ACO Passavant submersible motor pumps
- With pressure line outlet made of stainless steel and 1 (2) ball valve R ½", pressure line connection DN 40 or R 2", pressure line changeover outside to DN 50
- Dimensions from top of shaft to middle of pressure line: 1050 mm, positioned at 9 o'clock
- 1 inlet DN 150, dimension from bottom of shaft to middle of inlet: 775 mm, positioned at 3 o'clock (seal enclosed in separate pack)
- 1 connection port DN 100 for cable conduit/ventilation positioned at 6 o'clock and 12 o'clock connection height: 1439 mm from bottom of shaft to middle
- Connection port with socket R ½" for flushing connection (accessory)
- 1 manhole cover
 - Load class: D 400 (to EN 124)
 - Clear width: 600 mm
 - Without ventilation, incl. 2 operating keys
- With load distribution slab: 1550/625 x 200 mm made of reinforced concrete
- With connector
 - Height: 1400 mm
 - Height-adjustable, incl. seal
- Pressure line connection R 2" or 1½"
 - Ball-type retaining valve
 - Stainless steel piping and guide element to the above-water coupling
 - Stainless steel chain, length: 1.5 m
- ACO Passavant system
 - Official approval Z-42.1-418

Order information

Type	Description	Height [mm]	Usable volume up to [l]	Weight [kg]	Article No.
mono	Cover: placed loosley	3000	150	1060	0178.09.00
duo	Cover: screwed shut odour-proof	3000	150	1060	0178.09.01
mono	Cover: screwed shut odour-proof	3000	150	1080	0178.09.05
duo	Cover: odourproof bolted	3000	150	1080	0178.09.07

Dimensional drawing

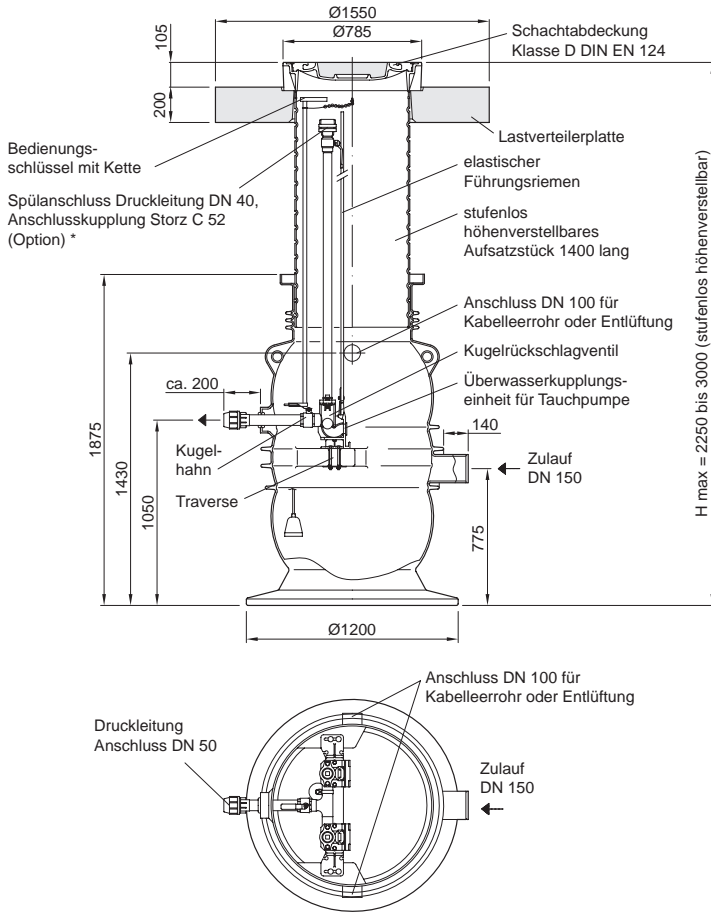

dargestellt:
Draufsicht Ausführung -duo

* nicht im Lieferumfang enthalten

Order information (pumps)

Pump	Impeller	Type of wastewater/ Operating mode	Weight [kg]	Article No.	
				mono	duo
Sita 200 N-ex	Grinder	Faecal/S1	38	0178.09.08	2 x 0178.09.08
Sita 260 N-ex	Grinder	Faecal/S1	45	0178.08.53	2 x 0178.08.53
Sita 300 N-ex	Grinder	Faecal/S1	60	0178.08.59	2 x 0178.08.59
Sat-V 75/2/50/D	Vortex impeller	Non-faecal/S3	22	0178.08.54	2 x 0178.08.54
Sat-V 150/2/50/D	Vortex impeller	Non-faecal/S3	30	0178.08.55	2 x 0178.08.55
Sat-100/D	Open impeller	Non-faecal/S1	30	0178.08.56	2 x 0178.08.56
Sat-150/D	Open impeller	Non-faecal/S1	32	0178.08.57	2 x 0178.08.57
Sat-200/D	Open impeller	Non-faecal/S1	32	0178.08.58	2 x 0178.08.58

Details of submersible pumps from page 64

Pumping stations

ACO Powerlift - P duo prefabricated pumping station Load class B 125/D 400



Product advantages

- Selected material combinations for longer service life
- Vertically installed ball retaining valve for reliable closing
- Overall installation depth up to 3000 mm
- Large usable volume – for surface drainage

Suitable for:

- Grey and black water
- Use downstream of grease separators up to NS 10

Product information

- Area of use
 - Downstream of separators
 - Detached and multi-dwelling houses
 - Surface drainage, e.g.:
 - Ramps, inner courtyards, etc.
 - Trade and industrial buildings
- Double pumping station for collecting and automatic lifting of faecal and non-faecal wastewater above the backflow level
- For installation below ground
- Tank made of polyethylene LLD-PE, Nominal diameter 1320 mm, clear width 1100 mm
- Traverse made of stainless steel
- Automatic underwater coupling for retaining ACO submersible pumps with coupling element
- Piping made of PVC-U
 - 1x ball valve G 2 made of PVC-U
 - 2x ball retaining valve G 2 made of cast iron EN-GJL
 - Flushing pipe connection option
- Pressure line connection (outside) with compression fitting DN 50 (adapter DN 70, DN 80 as accessory)
 - DN 50 for pipe outside Ø 63 mm
 - DN 70 for pipe outside Ø 75 mm
 - Dimension from bottom of tank to middle of pressure line 1295 mm, positioned at 3 o'clock
- 1x connection socket DN 150 with sealing element for inlet pipe, connection to EN 877, dimension from bottom of tank to middle of connection socket 1275 mm, positioned at 7:40 o'clock
- 2x connection socket DN 100 with sealing element for cable conduit/ventilation, connection to EN 877, dimension from bottom of tank to middle of connection socket 1360 mm, positioned at 4:15 and 10:15 o'clock
- Use of different level sensors due to universal level switching bracket
- Largely deposit free collection chamber with spherical bottom
- Adapter plate Ø 1000/625, H = 150 mm
- Shaft cover nominal size 600 - classes B 125/D 400 to EN 124, odourproof bolted, H = 125 mm
- Buoyancy proof where groundwater levels are up to 0.5 m below the ground level
- Due to a height-adjustable top section it can be installed up to a total installation depth of 3000 mm
- Installation depths (B 125/D 400):
 - T1 = min. 630 mm
 - T3 = min. 955 mm up to max. 1795 mm
- Top section D 400, cpl.
 - Top section H = 1600 mm
 - 2x sealing ring Ø 780 mm, 20 thick
 - 1x retaining ring Ø 810 mm, 30 thick
 - Load distribution slab Ø 1550/850, H = 200 mm

Order information

Load class	Type	Description	Usable volume up to [l]	Weight [kg]	Article No.
B 125	duo	<ul style="list-style-type: none"> ■ Traverse made of stainless steel ■ Pressure connection DN 50 for pipe outside Ø 63 mm 	550	450	0178.13.11
B 125 with top section	duo	<ul style="list-style-type: none"> ■ Traverse made of stainless steel ■ Pressure connection DN 50 for pipe outside Ø 63 mm 	550	1050	0178.13.12
D 400 with top section	duo	<ul style="list-style-type: none"> ■ Traverse made of stainless steel ■ Pressure connection DN 50 for pipe outside Ø 63 mm 	550	1050	0178.13.13

Dimensional drawing

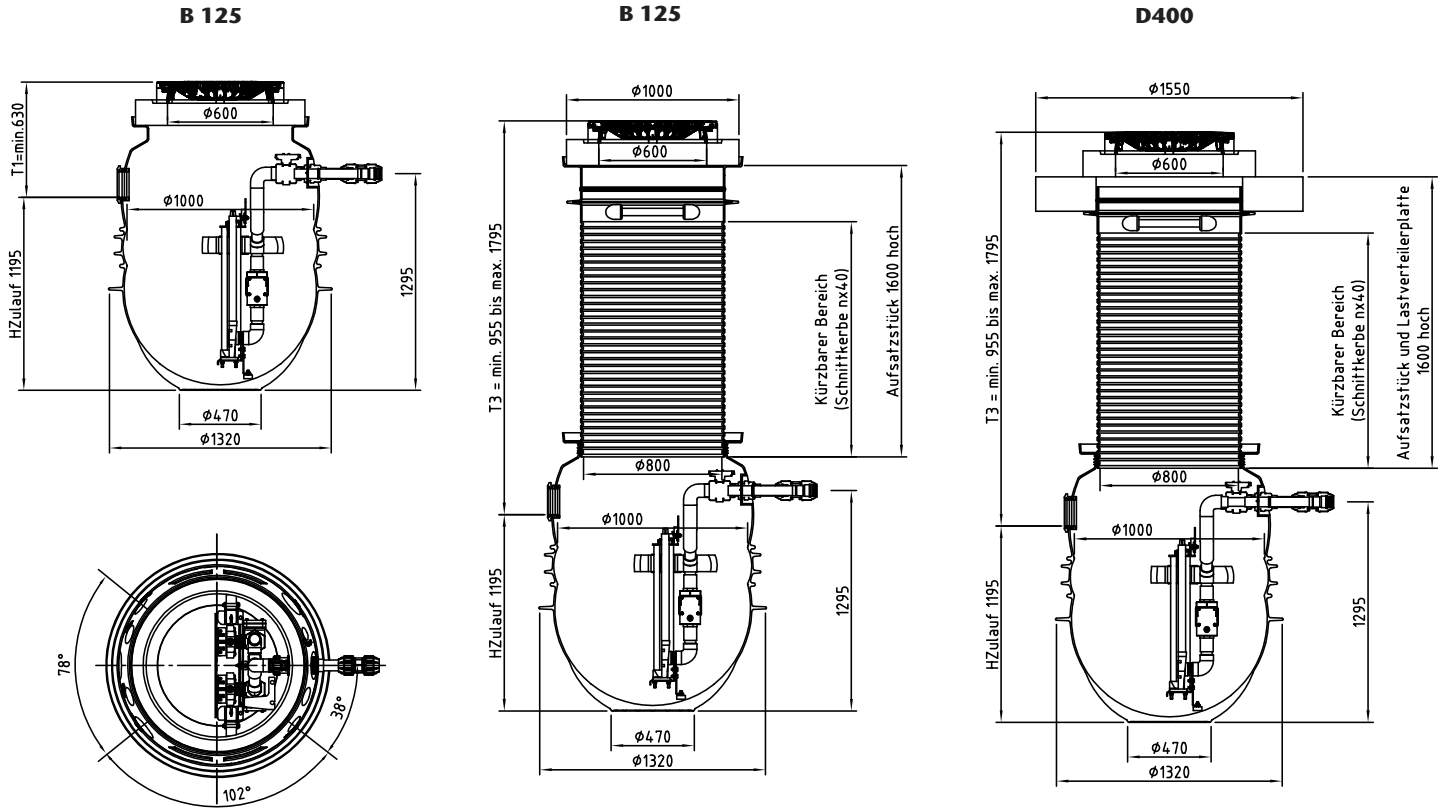

Order information (pumps)

Pump	Impeller	Motor rating [kW]	Type of wastewater/ Operating mode	Weight [kg]	duo
Sita 200 N-ex	Grinder	1.50	Faecal/S1	34	2 x 0178.12.85
Sita 300 N-ex	Grinder	2.20	Faecal/S1	44	2 x 0178.12.86
Sita 550 N-ex	Grinder	5.00	Faecal/S1	72	2 x 0178.12.87
Sat-100/D	Vortex impeller	0.88	Non-faecal/S1	24	2 x 0178.12.80
Sat-150/D	Vortex impeller	1.10	Non-faecal/S1	27	2 x 0178.12.81
Sat-200/D	Vortex impeller	1.50	Non-faecal/S1	28	2 x 0178.12.82

Details of submersible pumps from page 64

ACO Powerlift mono/duo pump kit



Product advantages

- Selected material combination for longer service life
- Preassembled piping
- Overall height and features adjustable using the modular principle
- Underwater coupling system with sliding tube

Suitable for:

- Grey and black water
- Use downstream of grease separators

Product information

- Areas of use
 - Downstream of separators
 - Detached and multi-dwelling houses
 - Surface water drainage, e.g. ramps, inner courtyards, etc.
 - Trade and industry parks
- Automatic underwater coupling for retaining ACO submersible pumps with coupling element
- Easier hanging and pulling out of the pumps due to sliding tube system
- Minimum installation area: 800 x 800 mm
- Use of different level sensors due to universal level switching bracket (see accessories)
- 4 m chain enclosed with the pump

■ Pump set DN 50

- Pressure line and ball valve made of PVC-U
- Backflow valve made of cast iron
- Pressure line connection DN 50 (OD=63 mm) with compression fitting (DN 70 or DN 80 as accessory)
- Optional horizontal or vertical pressure outlet (included in the scope of supply)

■ Pump set DN 100

- Backflow valve, Y-branch pipe, gate valve and transition elements made of cast iron
- Special adapter DN 100 for connection of the pressure line with 108 – 114.3 mm pipe outside diameter (optional 88 – 90 mm)
- Vertical pressure outlet

Order information

Type	Description	Article No.
mono	<ul style="list-style-type: none"> ■ Pressure line: DN 50 ■ Optional horizontal or vertical pressure outlet ■ With flushing pipe connection option 	0178.12.97
duo	<ul style="list-style-type: none"> ■ Pressure line: DN 50 ■ Optional horizontal or vertical pressure outlet ■ With flushing pipe connection option 	0178.12.96
mono	<ul style="list-style-type: none"> ■ Pressure line: DN 100 ■ Vertical pressure outlet ■ No flushing pipe connection option ■ Y-branch pipe and pressure outlet DN 100 (OD 110 mm) 	0178.13.06
duo	<ul style="list-style-type: none"> ■ Pressure line: DN 100 ■ Vertical pressure outlet ■ No flushing pipe connection option ■ Y-branch pipe and pressure outlet DN 100 (OD 110 mm) 	0178.13.05

Dimensional drawing

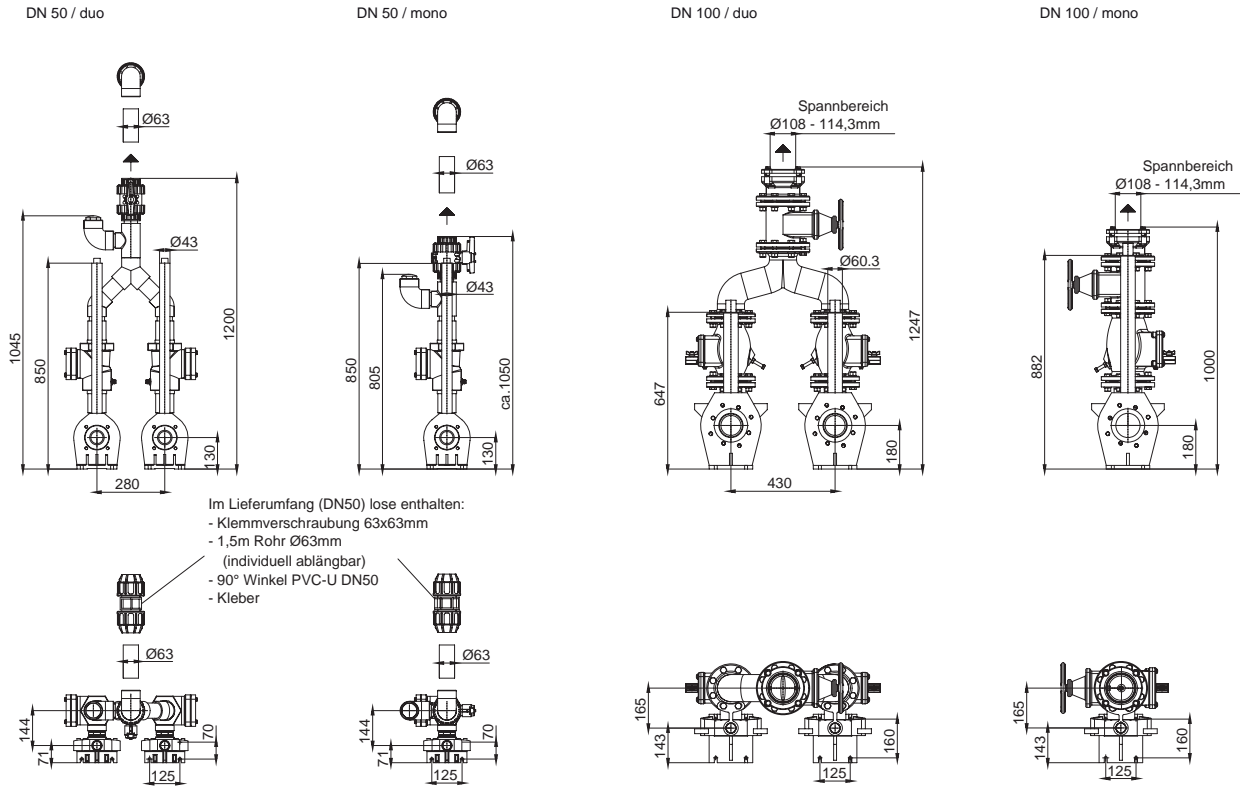

Order information (pumps)

Pump	Impeller	Nominal diameter	Motor rating [kW]	Type of wastewater/ Operating mode	Weight [kg]	mono	duo
Sita 200 N-ex	Grinder	DN 50	1.50	Faecal/S1	40	0178.12.85	2 x 0178.12.85
Sita 300 N-ex	Grinder	DN 50	2.20	Faecal/S1	50	0178.12.86	2 x 0178.12.86
Sita 550 N-ex	Grinder	DN 50	4.10	Faecal/S1	72	0178.12.87	2 x 0178.12.87
Sat 50/2/32	Multi-channel impeller	DN 50	0.37	Non-faecal/S3	11	0178.12.76	2 x 0178.12.76
Sat 75/2/32	Multi-channel impeller	DN 50	0.55	Non-faecal/S3	11	0178.12.77	2 x 0178.12.77
Sat-100/D	Vortex impeller	DN 50	0.88	Non-faecal/S1	24	0178.12.80	2 x 0178.12.80
Sat-150/D	Vortex impeller	DN 50	1.10	Non-faecal/S1	27	0178.12.81	2 x 0178.12.81
Sat-200/D	Vortex impeller	DN 50	1.50	Non-faecal/S1	28	0178.12.82	2 x 0178.12.82
KL-AT-M 200	Single channel impeller	DN 100	1.50	Faecal/S1	66	0178.12.88	2 x 0178.12.88
KL-AT-M 300	Single channel impeller	DN 100	2.20	Faecal/S1	86	0178.12.89	2 x 0178.12.89
KL-AT-M 400	Single channel impeller	DN 100	3.10	Faecal/S1	89	0178.12.90	2 x 0178.12.90
Sat-Q 300	Multi-channel impeller	DN 100	2.90	Non-faecal/S1	58	0178.12.91	2 x 0178.12.91
Sat-Q 400	Multi-channel impeller	DN 100	3.00	Non-faecal/S1	79	0179.12.92	2 x 0179.12.92
Sat-Q 550	Multi-channel impeller	DN 100	4.10	Non-faecal/S1	77	0178.12.93	2 x 0178.12.93

Details of submersible pumps from page 64

SITA for faecal and non-faecal wastewater



Product advantages

- Robust and efficient grinder
- Motor and medium side: Silicon carbide mechanical seal (SiC) with oil chamber
- Special hydraulic design prevents blockaging of the impeller
- With ATEX certification
- Winding protection

Areas of application

- Industrial, municipal and private sector
- Large delivery heads
- Long pressure lines to the sewer
- Black and grey water with short-fibre solids
- S1 operation = continuous operation/continuous running

Dimensional drawings

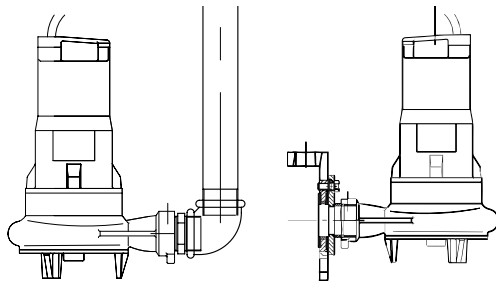

Multi-Max-F

Powerlift

Performance diagram

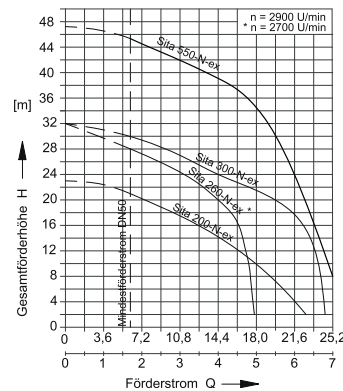

Order information

Type	Motor capacity		Characteristic data			Delivery line connection	Weight [kg]	Free ball passage	Switching on	Article No. suitable for Multi-Max F	Article No. suitable for Powerlift P and Powerlift pump kit DN 50
	P1 [kW]	P2 [kW]	Current consumption [A]	Voltage [V]	Speed [rpm]						
Sita 200 N-ex	2.1	1.5	3.7	400	2900	DN 50	34	–	Direct	0178.09.08	0178.12.85
Sita 260 N-ex	3.0	2.4	5.1	400	2700	DN 50	31	–	Direct	0178.08.53	–
Sita 300 N-ex	2.9	2.2	5.1	400	2900	DN 50	44	–	Direct	0178.08.59	0178.12.86
Sita 550 N-ex	5	4.1	8.7	400	2900	DN 50	72	–	Direct	–	0178.12.87

Cable type: S1RN8-F4G1.5+3x1 – 10 m
 Pressure outlet: Horizontal

KL-AT-M for faecal and non-faecal wastewater



Product advantages

- Open single-channel impeller
- Large ball passage
- Motor and medium side: Silicon carbide mechanical seal (SiC) with oil chamber
- Special hydraulic design prevents blockaging of the impeller
- With ATEX certification
- Winding protection

Areas of application

- Industrial, municipal and private sector
- Highly soiled grey and black water
- S1 operation = continuous operation/continuous running

Dimensional drawings

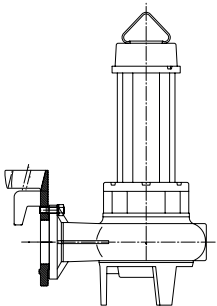

Powerlift

Performance diagram

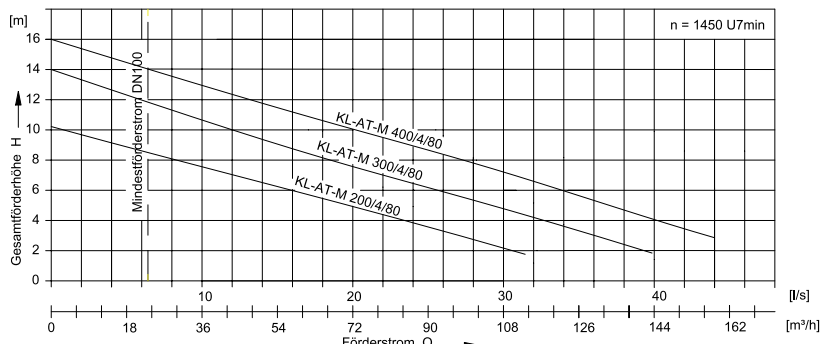

Order information

Type	Motor capacity		Characteristic data			Delivery line connection	Weight	Free ball passage	Switching on	Article No. suitable for Powerlift pump kit DN 100
	P1	P2	Current consumption	Voltage	Speed					
	[kW]	[kW]	[A]	[V]	[rpm]		[kg]			
KL-AT-M 200/4/80	2	1.5	4.1	400	1450	DN 80	66	80	Direct	0178.12.88
KL-AT-M 300/4/80	2.9	2.2	5.8	400	1450	DN 80	86	80	Direct	0178.12.89
KL-AT-M 400/4/80	3.7	3	7.3	400	1450	DN 80	89	80	Direct	0178.12.90

Cable type: S1RN8-F4G1.5+3x1 – 10 m
 Pressure outlet: Horizontal

SAT Q for non-faecal wastewater



Product advantages

- Open multi-channel impeller
- Large ball passage
- Motor and medium side: Silicon carbide mechanical seal (SiC) with oil chamber
- Thermal contact as winding protection

Areas of application

- Industrial, municipal and private sector
- Highly soiled grey water
- S1 operation = continuous operation/continuous running

Note: Exclusively usable for Powerlift installation kit DN 100

Dimensional drawings

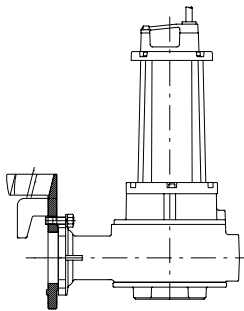

Performance diagram

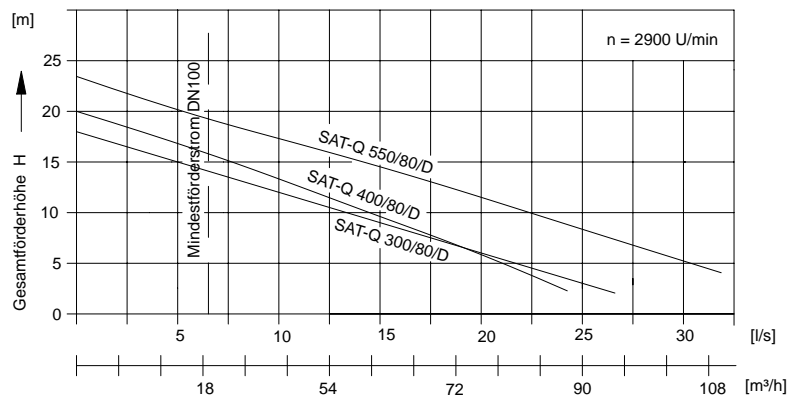

Powerlift

Order information

Type	Motor capacity		Characteristic data			Delivery line connection	Weight [kg]	Free ball passage	Switching on	Article No. suitable for Powerlift Pump kit DN 100
	P1 [kW]	P2 [kW]	Current consumption [A]	Voltage [V]	Speed [rpm]					
SAT-Q 300/80/D	3	2.9	5.1	400	2900	DN 80	58	40	Direct	0178.12.91
SAT-Q 400/80/D	4	3	6.7	400	2900	DN 80	79	45	Direct	0178.12.92
SAT-Q 550/80/D	5	4.1	8.7	400	2900	DN 80	77	45	Direct	0178.12.93

Cable type: S1RN8-F4G1.5+3x1 – 10 m
Pressure outlet: Horizontal

SAT-V for non-faecal wastewater



Product advantages

- Vortex impeller
- Large ball passage
- Medium side: Mechanical seal;
Motor side: Shaft sealing ring
- With ATEX certification

Areas of application

- Shaft and pit drainage
- Seepage water
- Industrial, municipal and private sector
- S3 operation = periodic intermittent operation

Dimensional drawings

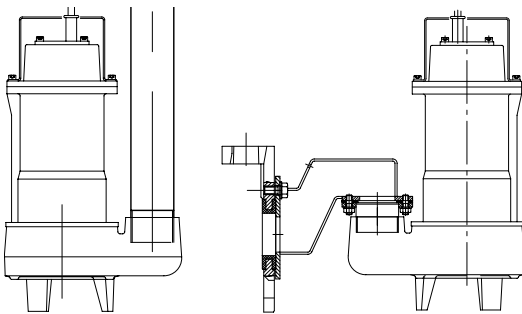

Multi-Max-F

Powerlift

Performance diagram

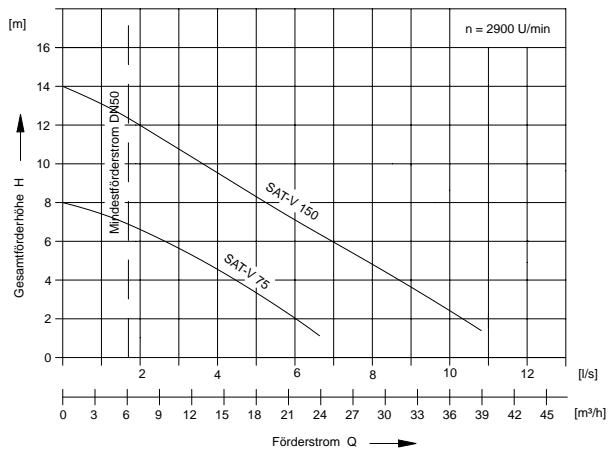

Order information

Type	Motor capacity		Characteristic data			Delivery line connection	Weight [kg]	Free ball passage	Switching on	Article No. suitable for Multi-Max F
	P1	P2	Current consumption [A]	Voltage [V]	Speed [rpm]					
	[kW]	[kW]								
SAT-V 75	0.7	0.55	1.3	400	2900	DN 50	14	40	Direct	0178.08.54
SAT-V 150	1.5	1.1	2.6	400	2900	DN 50	20	50	Direct	0178.08.55

Cable type: H07RN-F4G1 – 10 m
Pressure outlet: vertical

SAT for non-faecal wastewater



Product advantages

- Open multi-channel impeller
- Suction screen (dismountable)
- Medium side: Mechanical seal; Motor side: Shaft sealing ring
- Special hydraulic design prevents blockaging of the impeller

Areas of application

- In soakaway pits
- Shaft and pit drainage
- For backflow protection in case of floodwater
- Industrial, municipal and private sector
- S3 operation = periodic intermittent operation

Note: Not usable for Powerlift installation kit DN 100 and Multi-Max-F

Dimensional drawings

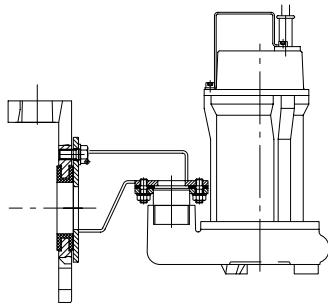

Performance diagram

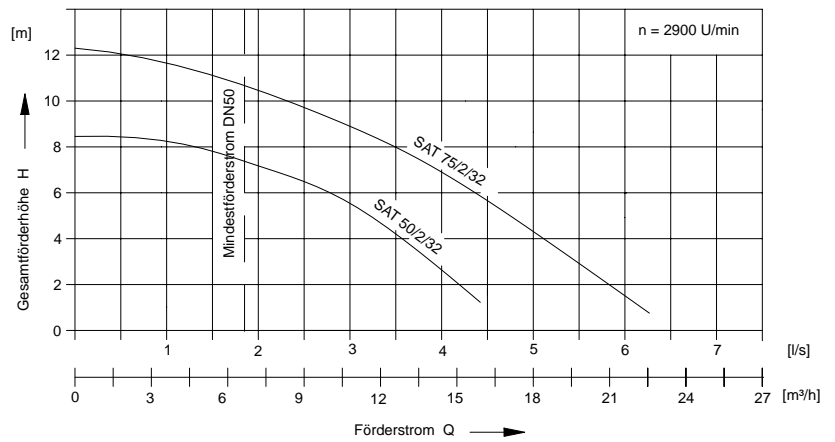

Powerlift

Order information

Type	Motor capacity		Characteristic data			Pressure line connection	Weight [kg]	Free ball passage	Switching on	Article No. suitable for Powerlift P and Powerlift pump kit DN 50	Version with float switch without attachments
	P1 [kW]	P2 [kW]	Current consumption [A]	Voltage [V]	Speed [rpm]						
SAT 50/2/32/D	0.94	0.37	1.1	400	2900	DN 50	11	10/20	Direct	0178.12.76	-
SAT 75/2/32/D	1.3	0.55	1.3	400	2900	DN 50	11	10/20	Direct	0178.12.77	-
SAT 50/2/32 WS	0.94	0.37	1.1	230	2900	R 1¼"	11	10/20	Direct	-	0159.06.63
SAT 75/2/32 WS	1.3	0.55	1.3	230	2900	R 1¼"	11	10/20	Direct	-	0159.06.67

Cable type: H07RN-F4G1 – 10 m
Pressure outlet: vertical

SAT for non-faecal wastewater



Product advantages

- Open multi-channel impeller
- Suction screen (demountable)
- medium side: Mechanical seal; Motor side: Shaft sealing ring
- Special hydraulic design prevents blockaging of the impeller

Areas of application

- In soakaway pits
- Surface water
- Industrial, municipal and private sector
- S1 operation = continuous operation/continuous running

Note: Not usable for Powerlift installation kit DN 100

Dimensional drawings

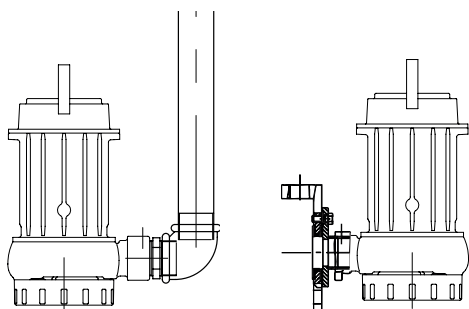

Muli-Max-F

Powerlift

Performance diagram

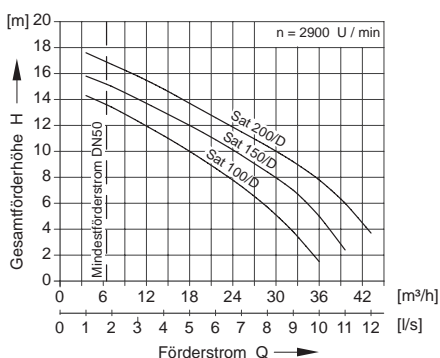

Order information

Type	Motor capacity		Characteristic data			Pressure line connection	Weight [kg]	Free ball passage	Switching on	Article No. suitable for Muli-Max F	Article No. suitable for Powerlift P and Powerlift pump kit DN 50
	P1 [kW]	P2 [kW]	Current consumption [A]	Voltage [V]	Speed [rpm]						
SAT 100	1.15	0.88	2.3	400	2900	R 2"	19.5	10/16	Direct	0178.08.56	0178.12.80
SAT 150	1.54	1.1	2.7	400	2900	R 2"	20.5	10/16	Direct	0178.08.57	0178.12.81
SAT 200	2.03	1.5	3.5	400	2900	R 2"	21.5	10/16	Direct	0178.08.58	0178.12.82

Cable type: H07RN-F4G1 – 10 m
 Pressure outlet: Horizontal

Accessories





Figure	Designation	Suitable for	Description	Article No.
	Switching device ACO Multi Control mono	<ul style="list-style-type: none"> ■ Multi-Max-F □ mono plant 	<ul style="list-style-type: none"> ■ For pumps up to 5.5 kW ■ Ready to plug in with 1.5 m connection cable ■ CEE 16 plug with phase-changing switch ■ 20 m pneumatic control line ■ Backpressure bell ■ Cable gland ■ Operating voltage: 400V, 50/60Hz ■ Control voltage: 230V/AC ■ Temperature range: -20 to +60 °C ■ Degree of protection IP 54 ■ Weight: 4.0 kg 	0178.63.79
	Switching device ACO Multi Control duo	<ul style="list-style-type: none"> ■ Multi-Max-F □ duo system ■ Powerlift-P 	<ul style="list-style-type: none"> ■ For pumps up to 5.5 kW ■ Ready to plug in with 1.5 m cable ■ CEE 32 plug with phase-changing switch ■ 20 m pneumatic control line ■ Backpressure bell ■ Cable gland ■ Operating voltage: 400V ■ Frequency: 50/60Hz ■ Control voltage: 230V/AC ■ Temperature range: -20 to +60° C ■ Degree of protection IP 54 ■ Weight: 6.0 kg 	0178.63.80
	Signalling unit	<ul style="list-style-type: none"> ■ Multi-Max-F ■ Powerlift-P 	<ul style="list-style-type: none"> ■ Self-charging ■ With floating contact ■ Visual and acoustic ■ Without contactor ■ For installation outside the Ex zone ■ Housing: 175 x 125 x 75 mm (L x H x D) ■ Degree of protection: IP65 ■ Operating voltage: 230 V/AC, 50/60Hz ■ Ready to plug in, with cable: 2 m 	0150.26.73
	Signalling unit with GSM module	<ul style="list-style-type: none"> ■ Multi-Max-F ■ Powerlift-P 	<ul style="list-style-type: none"> ■ Mains-independent alarm ■ Visual and acoustic alarm signalling ■ Freely configurable inputs <ul style="list-style-type: none"> □ 6 digital □ 2 analog ■ 1 alarm output 12V ■ Incl. GSM antenna (2.5 m cable) ■ Forwarding of the alarm to mobile phones by SMS text messaging ■ For installation outside the Ex zone ■ Housing: 178 x 125 x 102 mm (L x H x D) ■ Plug-in card for standard SIM card ■ Degree of protection: IP54 (with mounted antenna connector IP44) ■ Operating voltage: 230 V/AC, 50/60Hz 	0150.46.94
	Signal horn	<ul style="list-style-type: none"> ■ Signalling unit ■ signalling unit with GSM module 	<ul style="list-style-type: none"> ■ Operating voltage: 12V AC ■ Current consumption: 150 mA ■ 172 x 70 x 78 mm (L x W x D) ■ Degree of protection: IP33 ■ 92 dB(A) 	0150.58.14

Figure	Designation	Suitable for	Description	Article No.
	Signal horn	<ul style="list-style-type: none"> ■ Multi-Max-F switching devices ■ Wastewater lifting plants with ACO Multi Control switching device ■ Powerlift-P switching device 	<ul style="list-style-type: none"> ■ Operating voltage: 230V AC ■ Current consumption: 15 mA ■ Dimensions: 172 x 70 x 78 mm (L x W x D) ■ Degree of protection: IP33 ■ 92 dB(A) 	0178.61.94
	Air bubble injection	<ul style="list-style-type: none"> ■ Multi-Max-F ■ Powerlift-P 	<ul style="list-style-type: none"> ■ For increasing operating reliability (in case of formation of floating surface cover, e.g. in grease separators) ■ For pneumatic level switching (backpressure bell) ■ Mini compressor <ul style="list-style-type: none"> □ Connection: 230V □ Ready to plug in ■ With screw-in T-fitting ■ With retaining valve 	0150.25.45
	Outdoor cabinet	<ul style="list-style-type: none"> ■ Switching device ACO Multi-Control <ul style="list-style-type: none"> □ mono ■ Powerlift-P 	<ul style="list-style-type: none"> ■ Dimensions: 310 x 1460 x 207 mm (W x H x D) ■ With pre-fuse C16 (16A) ■ With 10 mm² PE terminals for equipotential bonding ■ Flashing light (impact resistant) ■ Closure device with security lock cylinder ■ Weight: 20 kg 	0178.63.84
	Outdoor cabinet	<ul style="list-style-type: none"> ■ Switching device ACO Multi-Control <ul style="list-style-type: none"> □ duo ■ Powerlift-P 	<ul style="list-style-type: none"> ■ Dimensions: 410 x 1460 x 207 mm (W x H x D) ■ With pre-fuse C25 (25A) ■ With 10 mm² PE terminals for equipotential bonding ■ Flashing light (impact resistant) ■ Closure device with security lock cylinder ■ Weight: 23 kg 	0178.63.85
	Outdoor cabinet	<ul style="list-style-type: none"> ■ Powerlift-P ■ Multi-Max-F 	<ul style="list-style-type: none"> ■ As empty housing ■ Dimensions: 410 x 207 x 1460 mm (L x W x H) ■ For installation of an on site backflow loop in DN 50 ■ Cabinet heating incl. thermostat, 230 V, 50 Hz ■ With security lock 	0178.62.35
	Outdoor cabinet for on-site pressure line and control	<ul style="list-style-type: none"> ■ Powerlift-P ■ Multi-Max-F 	<ul style="list-style-type: none"> ■ Dimensions: 2000 x 806 x 338 mm (H x W x D) ■ With reserve space for installation of an on-site backflow loop as per EN 12056-4 and DIN 1986-100 ■ DN 50 – DN 200 ■ With mounting plate incl. base ■ With lamp ■ With heating and thermostat ■ With security lock 	0178.64.16

Pumping stations

Accessories

Figure	Designation	Suitable for	Description	Article No.
	Outdoor cabinet for on-site pressure line	<ul style="list-style-type: none"> ■ Powerlift ■ Multi-Max-F 	<ul style="list-style-type: none"> ■ With reserve space for installation of an on-site backflow loop as per EN 12056-4 and DIN 1986-100 ■ With mounting plate incl. base ■ With heating and thermostat ■ With CEE and work socket with earth contact ■ Dimensions: 2000 x 806 x 335 mm (H x W x D) ■ DN 80/100/125/150 	0178.64.06
	Pressure pick-up	<ul style="list-style-type: none"> ■ ACO Multi-Control switching device □ mono □ duo 	<ul style="list-style-type: none"> ■ Consumption 4 – 20 mA ■ For reliable switching of cable lengths > 12 m ■ 0 – 200 mbar <p style="text-align: right;">Cable for installation: 20 m</p> <p style="text-align: right;">Cable for installation: 40 m</p>	0178.63.88 0178.63.87
	Safety barrier	<ul style="list-style-type: none"> ■ Pressure pick-up 	<ul style="list-style-type: none"> ■ For separating potentially explosive and safe area ■ Incl. housing 	0178.63.89
	Top section, short	<ul style="list-style-type: none"> ■ Multi-Max-F □ Load class: A 15/B 125 	<ul style="list-style-type: none"> ■ For increasing the installation depth ■ Total height: 2000 - 2350 mm ■ Incl. operating key ■ Weight: 22 kg 	0178.08.35
	Guide strap	<ul style="list-style-type: none"> ■ Top section □ 0178.08.35 	<ul style="list-style-type: none"> ■ Quantity required □ 1 for Multi-Max-F mono □ 2 for Multi-Max-F duo ■ Weight: 3 kg 	0178.08.79
	Top section, long	<ul style="list-style-type: none"> ■ Multi-Max-F □ Load class: A 15/B 125 	<ul style="list-style-type: none"> ■ For increasing the installation depth ■ Total height: 2000 - 3000 mm ■ Incl. operating key ■ Weight: 42 kg 	0178.08.36
	Guide strap	<ul style="list-style-type: none"> ■ Top section □ 0178.08.36 	<ul style="list-style-type: none"> ■ Quantity required □ 1 for Multi-Max-F mono □ 2 for Multi-Max-F duo ■ Weight: 4 kg 	0178.08.80
	Flushing connection	<ul style="list-style-type: none"> ■ Multi-Max-F 	<ul style="list-style-type: none"> ■ Total height: 430 mm ■ Weight: 5 kg 	0178.05.22

Figure	Designation	Suitable for	Description	Article No.
	Vacuum relief valve	<ul style="list-style-type: none"> ■ Multi-Max-F 	<ul style="list-style-type: none"> ■ Only possible in conjunction with flushing connection ■ Weight: 1.5 kg 	0178.09.31
	Float switch	<ul style="list-style-type: none"> ■ Submersible pumps □ SAT (non-faecal wastewater) 	<ul style="list-style-type: none"> ■ 4 are required! ■ Housing made of plastic, polypropylene material ■ Connection cable: 10 m ■ Degree of protection: IP 68/2 bar ■ Switching capacity: 5 A/250V ■ Switching angle: 10° ■ Restriction: Not approved for use in potentially explosive atmospheres 	0159.12.46
	Extension Guide pipe DN 50	<ul style="list-style-type: none"> ■ Powerlift installation kit DN 50 ■ Powerlift -P 	<ul style="list-style-type: none"> ■ Length: 1 m ■ Material: PVC-U ■ For easy installation of pumps in deep shafts or if using a top section ■ Incl. adapter, guide pipe and threaded rod 	0178.12.78
	Extension Guide pipe DN 100	<ul style="list-style-type: none"> ■ Powerlift installation kit DN 100 	<ul style="list-style-type: none"> ■ Length: 1 m ■ Material: Stainless steel ■ For easy installation of pumps in deep shafts ■ Incl. adapter, guide pipe and threaded rod 	0178.12.79
	Compression fitting 63 x 63 mm	<ul style="list-style-type: none"> ■ Powerlift installation kit DN 50 ■ Powerlift -P 	<ul style="list-style-type: none"> ■ Material: PP ■ PN16 ■ for extending the length of pressure lines with 63 mm diameter 	0150.38.38
	Compression fitting 63 x 75 mm	<ul style="list-style-type: none"> ■ Powerlift installation kit DN 50 ■ Powerlift -P 	<ul style="list-style-type: none"> ■ Material: PP ■ PN16 ■ For extending the pressure line diameter from 63 mm to 75 mm 	0178.13.09
	Compression fitting 63 x 90 mm	<ul style="list-style-type: none"> ■ Powerlift installation kit DN 50 ■ Powerlift -P 	<ul style="list-style-type: none"> ■ Material: PP ■ PN16 ■ For extending the pressure line diameter from 63 mm to 90 mm 	0178.13.10
	Installation kit, level measurement retainer	<ul style="list-style-type: none"> ■ Powerlift installation kit 	<ul style="list-style-type: none"> ■ For retaining / fixing float switches, backpressure bell, or pressure pick-up ■ Incl. fixing material & glands 	0178.12.94
	Toroidal sealing ring	<ul style="list-style-type: none"> ■ Powerlift installation kit DN 100 	<ul style="list-style-type: none"> ■ As supplementary component for pressure line DN 80 	0159.37.97



ACO service advantages

Each project is different, it has its own requirements and challenges. Apart from our products, we also offer you our know-how and services, to develop tailor-made solutions together – from the design through to support following completion.

train: **Information and further training**

In the ACO Academy we share the know-how of the worldwide ACO Group with architects, design engineers, installers and traders, for whom quality is important. We invite you to profit from this.

design: **Design and optimisation**

The specification and design of drainage solutions allows many variations. Yet which concept produces the economically best and technically most reliable solution? We help you to find the right answer.

support: **Construction advice and support**

To ensure that no unpleasant surprises occur between the design and implementation of a drainage solution, we advise and assist you for a specific project on your construction site.

care: **Inspection and maintenance**

ACO products are designed and produced for a long life. With our after-sales offers we ensure that ACO continues to fulfil your high quality standards for many years.

ACO Building Drainage on the internet

The <http://catalogue.aco-haustechnik.de/en/Home> website provides plenty of information on lifting plants and pumping stations so that you can quickly search for something for your clients.

Online catalogue

With the new online catalogue on our website you can easily download dimensioned drawings and tender specification texts. Here the product can be chosen by using appropriate selection criteria.

- Product finder
- Simple keyword search and article number
- Tender specification texts (TXT, Datanorm and GAEB)
- Dimensioned drawings (DXF)
- Product illustrations
- Installation and assembly instructions

<http://catalogue.aco-haustechnik.de/en/Home>

eServices

Wastewater lifting plant design

With the help of the dimensioning tool for wastewater lifting plants you can determine the suitable plant for your special application case. This is done by entering a few parameters under:

<http://catalogue.aco-haustechnik.de/en/Home/Dimensioning-tools>

You determine the suitable wastewater lifting plant in only three steps

- Enter the on site use conditions
- Select a lifting plant with corresponding usable volume
- Design and dimensioning of the pumps
- Output of the calculated values and filling in of the PDF form

Video

ACO lifting plants

<http://aco.me/hebeanlagen>



ACO 360° service – everything from a single stop

The 360° service of ACO Building Drainage offers you a comprehensive product portfolio, from technical advice and sale, through to the conclusion of maintenance agreements. We are also there for you during the putting into service and startup directly on the operator company's premises.

We assist you with the procurement of spare parts and repair all "service relevant" products. We are also your contact if you are planning structural alterations or modernisation work.

Our services

- Technical advice and sale
- Startup of the plants
- Maintenance according to standard
- Fast repairs
- Premium maintenance agreements incl. 5 year warranty and free replacement of parts

On site service

The service on site is carried out by our 32 certified service partners with 120 trained fitters, so that we can satisfy all requirements as quickly as possible and comprehensively. Together with eight other own fitters we are thus able to respond quickly to your wishes. We hold regular training courses in our factory in Stadtlengsfeld, in order to keep our service technicians and fitters up-to-date at all times. Here we reconstruct real installation situations and train directly with the product.



ACO is your systems provider for putting into service and maintenance

From the startup to maintenance, from repairs to structural alterations and modernisation – with ACO you receive everything you need from a single source. Three new maintenance agreements with the ACO Building Drainage service professionals ensure you maximum operational reliability with calculable costs.

Permanently reliable operation of the plant is only ensured if proper maintenance is carried out at regular intervals; these are specified in the DIN/EN standards listed below:

- Grease separators see DIN 4040 Part 100 and EN 1825-2
- Wastewater lifting plants see DIN 1986 Part 100 and EN 12056
- Backflow protection see DIN 1986 Part 3

Basic maintenance agreement

ACO Services

- General checking of condition and inspection of the plant
- Checking the functionally relevant components for visible corrosion and other signs of ageing
- Documentation of the inspection results in a status report

Comfort maintenance agreement

ACO Services

- All services from the Basic maintenance agreement
- Maintenance of the plants as per the individual plant maintenance schedule
- Small materials and sealing materials up to a value of € 25.00 excl. VAT per plant to be serviced
- Documentation of the maintenance results in a maintenance report
- Service partner's travel costs to and from site included

Premium maintenance agreement

ACO Services

- All services from the Comfort maintenance agreement
- Safety inspection, maintenance as per individual plant maintenance schedule
- Delivery and installation of the required wearing parts
- Documentation of the maintenance results
- Restoration of the specified condition of the plant(s) with necessary repairs
 - Within 48 hours (optional)
- Service partner's travel costs to and from site included
 - If the maintenance agreement is concluded from startup of the plant(s) the guarantee (warranty) period is extended from 2 to 5 years



Each product of ACO Building Drainage supports the ACO system chain

collect

- Floor drainage
- Bathroom drainage
- Roof drainage
- Parking deck drainage
- Balcony and terracedrainage
- Pipe systems

clean

- Grease separators
- Starch separators
- Light liquid separators
- Process engineering

hold

- Backflow preventers

release

- Lifting plants
- Pumping stations

ACO Passavant GmbH

Im Gewerbepark 11c
D 36457 Stadtlengsfeld
Tel. 036965 819-0
Fax 036965 819-361
www.aco-haustechnik.de